



Domino G-Series **Product Manual**

G20i

THIS PAGE INTENTIONALLY LEFT BLANK

DOMINO G-SERIES PRINTER PRODUCT MANUAL

This manual, Domino Part No. EPT024619, is for use in the operation and maintenance of Domino G20i printers.

For basic instructions on how to operate the printer, refer to the Domino G20i Operator's Quick Reference Guide, Domino Part No. EPT024620.

Users of this printer are warned that it is essential to read, understand and act according to the information given in Part 1 : Health and Safety. This part of the manual also specifies a set of symbols which are used elsewhere in the manual to convey special warnings or requirements. It is, therefore, essential that users are also familiar with these symbols and act accordingly.

All rights reserved. No part of this publication may be reproduced, stored on a retrieval system, or transmitted in any form, or by any means, electronic, mechanical, photocopying, recording or otherwise, without the prior permission of Domino Printing Sciences plc.

Domino Printing Sciences plc has a policy of continuous product improvement, the Company therefore reserves the right to modify the specification contained in this manual without notice.

© Domino Printing Sciences plc 2017.

For technical support refer to www.DominoCaseCoding.com or contact your local Domino Channel.

Domino UK Ltd.

Trafalgar Way
Bar Hill
Cambridge
CB23 8TU
United Kingdom
Tel: +44 (0) 1954 782551

FCC Notice

This equipment has been tested and found to comply with the limits for a Class A digital device, pursuant to Part 15 of the Federal Communication Commission (FCC) Rules. These limits are designed to provide reasonable protection against harmful interference when the equipment is operated in a commercial environment.

This equipment generates, uses and can radiate radio frequency energy and, if not installed and used in accordance with the instruction manual, may cause harmful interference to radio communication. Operation of this equipment in a residential area is likely to cause harmful interference, in which case, the user will be required to correct the interference at his own expense.

If this equipment does cause harmful interference to radio or television reception, which can be determined by turning the equipment off and on, the user is encouraged to try to correct the interference by one or more of the following measures:

- Re-orientate or relocate the receiving antenna.
- Increase the separation between the equipment and receiver.
- Connect the equipment into an outlet on a circuit different from that to which the receiver is connected.
- Consult the dealer or an experienced radio/TV technician for help.

Any changes or modifications not expressly approved by the manufacturer could void the user's authority to operate the equipment.

EMC Statement

This device may malfunction when operated in a location very close to a wireless telecommunication device such as a mobile phone, Wi-Fi or Bluetooth device.

Class A (Broadcasting and Communication Equipment for Business)

Sellers and users should note that this equipment is an electromagnetic device for business (class A), and this is for use outside of the house.

This device will not be able to provide services related to personal safety due to possible radio interference.

THIS PAGE INTENTIONALLY LEFT BLANK

CONTENTS

PART 1	HEALTH AND SAFETY
PART 2	DESCRIPTION
PART 3	OPERATION
PART 4	FAULT FINDING
PART 5	MAINTENANCE
PART 6	INSTALLATION

AMENDMENT RECORD

Amendment	Date
All Parts at issue 1	June 2016
All Parts at issue 2	November 2016
All parts at Issue 3	December 2016
All Parts at issue 4	April 2017
All Parts at issue 5	September 2017

PART 1 : HEALTH AND SAFETY

CONTENTS

	Page
INTRODUCTION	1-3
Basic Requirements	1-3
Fire Risk	1-5
Spillages and Disposal	1-5
G-SERIES SYMBOLS	1-6

THIS PAGE INTENTIONALLY LEFT BLANK

INTRODUCTION

Domino supplies Safety Data Sheets (SDS) giving specific safety information with each of its inks. The following notes are for general guidance only.

Basic Requirements

- Read the relevant Safety Data Sheet (SDS) before storing, handling, transporting or using the ink cartridges.
- Disconnect the power before making any wiring connections.
- Ensure all cables are secured away from moving production line components.
- Use only lint free wipes when cleaning the cartridge nozzles.
- Clean cartridge nozzles according to the enclosed recommendations.
- Protect the print heads from impact with proper adjustment and alignment of side rails and product guides.
- Do not open any enclosed components of the printer or print heads. They contain no user-serviceable parts.
- Wear suitable protective equipment when operating the G20i.
- The G20i is for indoor use only, do not operate the printer outdoors, or in an environment outside of the specified operating range.

HEALTH AND SAFETY

When used correctly, printing inks do not cause problems. However, everybody using them should be familiar with the appropriate safety standards and be aware of the precautions that should be taken. The following are basic requirements:

- Proper standards of industrial practice relating to cleanliness and tidiness must be maintained.
- Inks cartridges must be stored and handled with care.
- Smoking or the use of naked flames (or other sources of ignition) in the vicinity of any inks or solvents is highly dangerous and therefore strictly inadvisable.
- All who come into contact with inks must be properly instructed in their use.

Directions for safe working practices vary according to the environment. The following are broad principles so that necessary precautions may be taken:

- Contact with the mouth must be avoided. Therefore eating, drinking or smoking, or any personal habits or actions which may transfer ink to the mouth, must be avoided.
- Contact with the eyes must be avoided. If ink does get into the eyes, first aid treatment is to flood the affected eye for 15 minutes with saline solution, (or clean water if saline solution is not available), taking care not to allow the water to run into an unaffected eye. Medical aid must be obtained immediately. Eyewash is available from Domino (Pt.No. 99200).
- Certain G-Series inks contain solvents which may injure the skin. Good working practice must always be employed and risk assessments carried out. Safety Data Sheets are available that give advice on personal protective equipment. Most gloves only offer limited and short term exposure protection and must be changed after any splashing and on a frequent basis.
- Any used cleaning materials, e.g. rags, paper wipes, are a potential fire hazard. They must be collected for safe disposal after use.
- After exposure to ink, all possible traces must be washed off as soon as possible at the nearest washing facility.

Fire Risk

For an electrical fire, do not use water. If water must be used, such as in the case of a Nitro-cellulose ink fire (see below) the power **MUST BE REMOVED** first.

Fire risk is a most important consideration where printing inks are stored and used. The degree of fire hazard will vary considerably from one type of ink or wash to another.

Water-based inks will not burn, although inks based on water-alcohol mixtures may burn if there is sufficient alcohol present. Prolonged exposure of water-based systems to high temperatures may evaporate the water to give a flammable residue.

Solvent-based inks offer a greater degree of hazard depending on the particular solvent or solvent combination. When there is a particular hazard the appropriate information is given on the SDS.

If there is a fire, there is a likelihood that dangerous fumes will arise from printing inks. For this reason ink must be stored where it can be reached quickly by the fire fighting service, and where it will not spread beyond the store.

Spillages and Disposal

WARNING: **Some dried inks are highly flammable. Clean up all ink spillages immediately. Do not allow the ink to dry or allow any build-up of dried ink spills.**

Spillages must be cleaned up as soon as possible with the appropriate solvent materials and with regard to the safety of personnel. Care must be taken to prevent spillages or residue from cleaning up entering drains or sewage systems.

Inks and associated fluids are materials which conduct electricity. Therefore, power to the printer must be switched off while spillages inside the printer cabinet are being cleaned up.

Printing inks and associated fluids must not be treated as ordinary waste. They must be disposed of using approved methods according to local regulations.

G-SERIES SYMBOLS

The following symbols are used in this manual. Where they appear next to a procedure or instruction, they have the significance and importance of written warnings and cautions.



Eye protection must be worn.



Protective clothing must be worn. Use adequate protective gloves. Consult the relevant Safety Data Sheet (SDS).



The equipment must be switched off and power removed.



Only trained personnel should carry out this procedure.



Beware of Electrostatic Discharge (ESD). Electrostatic precautions must be used.

- Switch off machine first
- Wear a wristband connected to the ESD connector provided
- Avoid wearing clothing which can build up electrostatic voltages
- Use ESD protective bags to transport PCBs
- Only place PCBs on a mat made from a material which will dissipate electrostatic voltages and which is connected to ground.

PART 2 : DESCRIPTION

CONTENTS

	Page
INTRODUCTION	2-3
General	2-3
PRINTER DESCRIPTION	2-4
Android Device Requirements	2-4
PC Requirements	2-4
Printer Specification	2-5
Printer Connections	2-6
Printer Status Lights	2-7
PRINTER CONTROL	2-8
Wireless USB Keyboard Interface	2-9
Main Menu	2-9
Message Menu	2-10
Operation Menu.....	2-11
Settings Menu	2-12
PC Interface	2-14
Printer Control Screen	2-14
Designing Screen	2-17
Tool Menu.....	2-19
Android Device Interface	2-20

DESCRIPTION

THIS PAGE INTENTIONALLY LEFT BLANK

INTRODUCTION

General

This manual provides:

- A basic introduction to the G20i.
- Details of the menu structure.
- Instruction for message creation.
- Preventative maintenance procedures.
- Fault finding and diagnosis.
- Details on updating software, transforming messages, logos and fonts.
- Installation instructions.



Domino G20i Thermal Ink Jet Printer

DESCRIPTION

PRINTER DESCRIPTION

The G20i is a compact thermal ink jet printer, intended for printing data on user supplied products on manufacturing production lines.

The G20i uses a Domino BK640 ink cartridge as the print engine.

The G20i can be controlled with a wireless USB keyboard, an Android device via Bluetooth or a PC connected via USB.

Android Device Requirements

Minimum Android device requirements:

Operating System:	Android version 4.0 and up.
Connectivity:	Bluetooth

PC Requirements

Minimum PC requirements:

CPU:	Core 2 Duo 2x2.0 GHz
Ram:	2GB
Hard Drive Space:	50MB
Operating System:	Windows 7, Windows 8, Windows 10 (32, 64 bits), (Microsoft .NET Framework 4)

DESCRIPTION

Printer Specification

Display:	LCD 2.8" automatic rotation
Dimensions:	Length:107.5mm (4.23") Width: 74.5mm (2.93") Depth: 83mm (3.27")
Weight:	450g
Power Supply:	Input: 100V - 240V AC, 50/60Hz, 1.4A Output: 12V, 5.0A, 60W
Maximum Power Consumption:	48W
Maximum Printing Resolution:	600 X 600 DPI (When using a PC to control the G20i) 300 X 300 DPI (When using an Android device or wireless USB keyboard to control the G20i)
Print Speed:	76m/min at 300 x 300 dpi
Print Density:	5 levels
User Interface:	PC, Wireless USB Keyboard or Android device via Bluetooth
Message Memory:	Up to 100 messages
Ink Solution:	Aqueous and Solvent
Menu Language:	Multiple / selectable
Printable Characters:	Windows true fonts with PC connection
Maximum Number of Lines:	6
Maximum Character Height:	Maximum 12.7mm (0.5")
Throw Distance:	Up to 6mm (0.23")
Printable Data Types:	Alphanumeric Text, Symbols, Logos, Date/ Time, Expiry Date, Counters, Shift Codes and Barcodes.
Temperature Range:	+5°C to +50°C (+41°F to +122°F)
Humidity Range:	10% to 90% non-condensing

Printer Connections

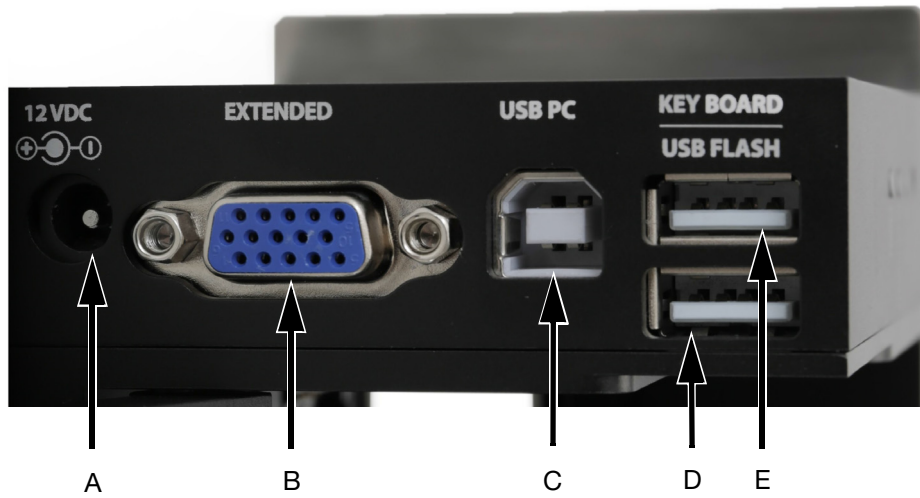

Printer Connections

A	12V DC power supply input.
B	Serial connection for an external product sensor, shaft encoder, alarm beacon, etc.
C	USB-B port for PC connection.
D	USB flash port for updating firmware, fonts and logos.
E	USB port for the wireless USB keyboard receiver.

Printer Status Lights

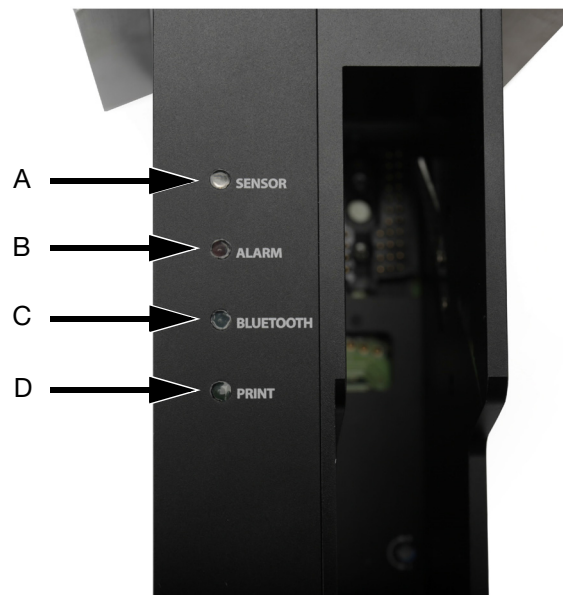

Printer Status Lights

A	<p>Sensor LED Activated when the printer receives a signal from a product sensor.</p> <p>Red light = Internal Product Sensor Green light = External Product Sensor</p>
B	<p>Alarm LED Activated when an error occurs.</p>
C	<p>Bluetooth LED Activated when a Bluetooth device is connected to the printer.</p>
D	<p>Print LED Activated during message printing.</p>

DESCRIPTION

PRINTER CONTROL

The G20i can be controlled using 3 different user interface types:



*Wireless USB 2.0 Keyboard and LCD Screen,
as described on [page 2-9](#).*

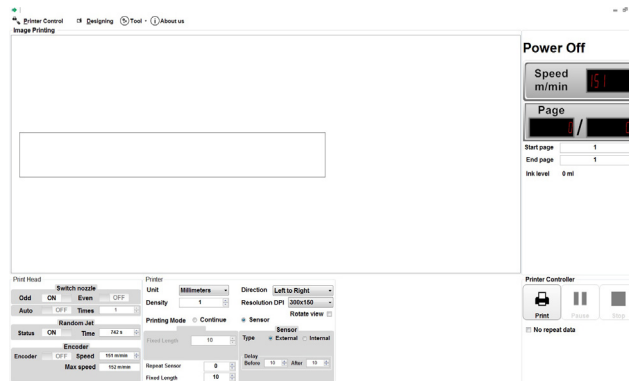

*PC with the Domino G20i PC application installed,
as described on [page 2-14](#).*

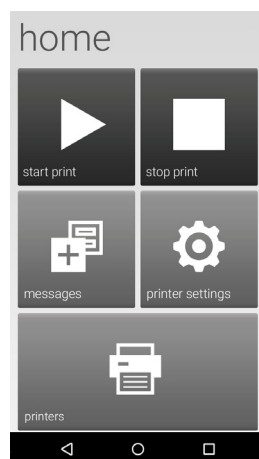

*Android device with the Domino G20i application installed,
as described on [page 2-20](#).*

Wireless USB Keyboard Interface

Main Menu

When starting the printer, the following *Main menu* screen is displayed on the G20i's LCD screen.

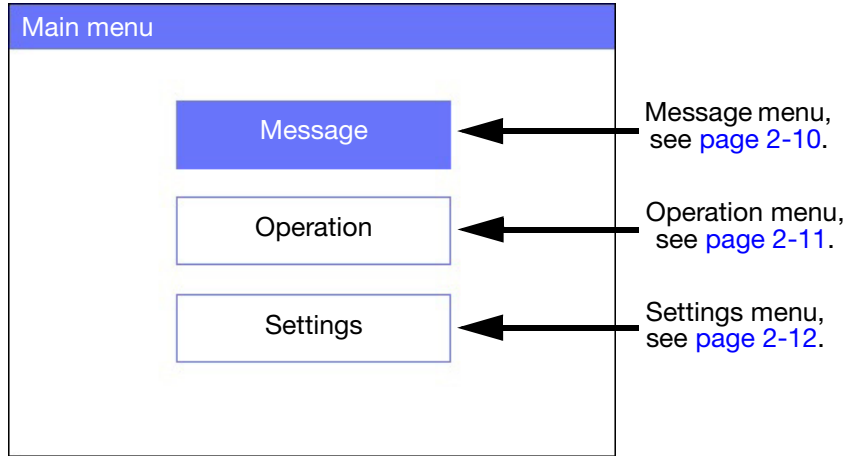

Main Menu Screen

The table below defines the function of the wireless USB keyboard buttons. The Wireless USB keyboard is used to navigate menus and input data on the G20i's LCD screen.

Enter	Confirm, save or apply a setting.
ESC	Go to the previous screen.
←/→	Move the cursor left or right.
↑/↓	Move the cursor up or down.
Tab	Hold the Tab button to move the cursor faster.
Home/End	Move the cursor to Home or End.
Shift	Hold the Shift button to input upper-case characters.
Insert	Press the Insert button during message creation to insert a Symbol, Logo, Counter, Date, Time, String, or Barcode into the message design.
Backspace	Delete a message field from the right.

DESCRIPTION

Message Menu

The *Message menu* contains the following items:

Create New	Create a new message.
Open	Open an existing message to print, edit or delete.
Information	Display the current printer settings: <ul style="list-style-type: none">• Ink Level• Speed• Density• Resolution• Delay Before (The distance between a product sensor triggering a print, and the message being printed.)• Delay After (The distance between printed messages.)• Print Mode• Repeat• Minimum (The minimum number of prints that can be made with the current ink level and settings.)

DESCRIPTION

Operation Menu

The *Operation menu* contains the following items:

Start / Stop	Start or Stop printing.
Purge	Purge the print head to clear blocked nozzles.
Connect PC / Disconnect PC	Connect or Disconnect the G20i to a PC.

DESCRIPTION

Settings Menu

The *Settings menu* contains the following items:

Speed	Setup an encoder to measure the production line speed. Or, enter a manual value for the production line speed.
Resolution	Set the print resolution.
Density	Set the print density.
Delay	Set the distance between when the print trigger is activated and when a message will be printed. And, set the distance between printed messages.
Cartridge	Manually enter the quantity of ink in the ink cartridge, and display the ink type.
Update Logo	Update a logo or image from a USB stick to the printer's internal memory.
String	Create and update strings of text which can be inserted into messages.
Purge	Purge the print head at regular intervals to prevent print head nozzles from blocking during periods of inactivity.
Print Side	Select which row of nozzles will be used for printing, or automatically switch nozzle rows.
Sensor	Select whether the internal, or an external product sensor is used to trigger message printing.
Directions	Set the print direction.
Print Mode	Set the print mode / trigger.
Unit	Select the unit of measurement. (mm or inch)
Bluetooth	Enable, disable and setup the Bluetooth connection to control the G20i from an Android device.
Update Font	Update the font type.
Rollover	Enable or disable a different time value depending on the production shift schedule. (The default time value is 00:00)
System clock	Set the time and date for the system clock.
Rotate	Select screen modes. (Auto rotate or Lock rotate)

DESCRIPTION

Password	Set password protection to prevent unauthorized access to printer settings.
Default	Reset the G20i to factory default settings.
Language	Select the interface language.
IO signals	Enable or Disable an optional remote start / stop button.
Custom string	Update and view custom text strings.
Coder name	View and edit the printer name.
RS485	Enable, disable and configure RS485 network settings.
LCD BackLight	Adjust the LCD backlight time out function.
Reset	Reset counters in messages to their reset value.
About	Display the current printer software version and update the printer software.

DESCRIPTION

PC Interface

To connect the G20i to a PC, see “PC Connection and Software Installation” on page 6-16.

Printer Control Screen

When starting the Domino G20i PC application, the following *Printer Control* screen is displayed.

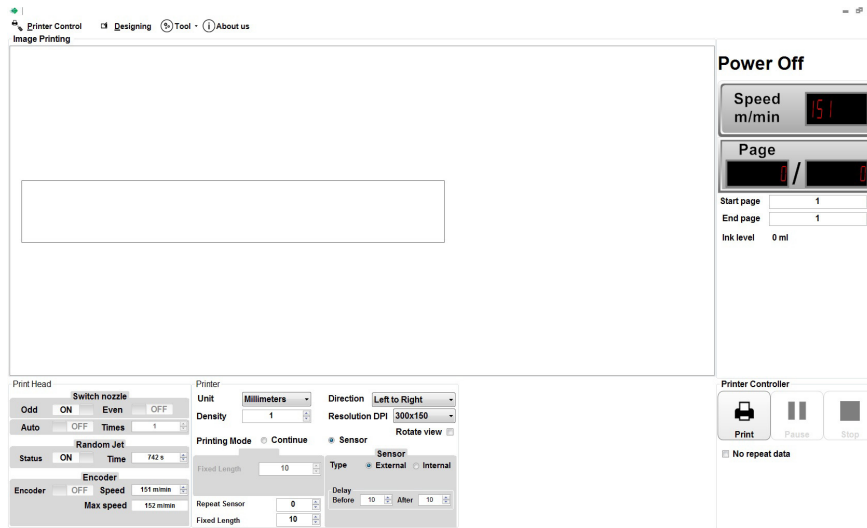

Domino G20i PC Software

The *Printer Control* screen contains the following items:

Sub Menu	Setting Name	Explanation
Task Bar	Printer Control	Click on <i>Printer Control</i> , to return to the Printer Control menu from other menus.
	Designing	Create and edit message templates, see page 2-17 .
	Tool	Tools to purge the print head, monitor the event log, calculate ink cost and convert logos, see page 2-19 .
	About us	View the software version and view contact details for Domino Printing Sciences plc.

DESCRIPTION

Sub Menu	Setting Name	Explanation
Print Head	Switch nozzle <ul style="list-style-type: none"> • Odd • Even 	Manually select which nozzle side will be used for printing.
	Switch nozzle <ul style="list-style-type: none"> • Auto • Times 	Automatically switch nozzle sides between prints.
	Purge <ul style="list-style-type: none"> • Status • Time 	Purge the print head at regular intervals to prevent print head nozzles from blocking.
	Encoder <ul style="list-style-type: none"> • Encoder • Speed • Max speed 	<p>The <i>Encoder</i> setting is used to enable or disable a shaft encoder.</p> <p>The <i>Speed</i> setting is used to manually set the print speed if a shaft encoder is not in use.</p> <p><i>Max speed</i>, displays the maximum achievable printing speed with the printers current settings.</p>
Printer	Unit	Select the measurement unit.
	Direction	Select the print direction.
	Density	Select the required print density.
	Resolution DPI	Select the required print resolution.
	Rotate View	Print the message upside down.
	Printing Mode	Configure the print trigger settings.









DESCRIPTION

Sub Menu	Setting Name	Explanation
Printing Status	Power On/Off	Displays whether the printer is powered On or Off.
	Speed m/min	Displays the current print speed.
	Page	Displays the number of messages printed, compared to the number of messages still to print.
	Start page	Select which page to start printing from.
	End page	Select which page to end printing on.
	Ink level	Displays the quantity of ink in the ink cartridge.
Printer Controller	Print	Select <i>Print</i> to start printing.
	Pause	Select <i>Pause</i> to pause printing.
	Stop	Select <i>Stop</i> to stop printing.
	No repeat data	Tick the <i>No repeat data</i> tick box to stop message data being repeated.







DESCRIPTION

Designing Screen

The *Designing* screen contains the following items:

<p>New Template</p> 	<p>Create a new message template.</p>
<p>Edit Template</p> 	<p>Edit an existing message template.</p>
<p>Open</p> 	<p>Open a saved message template on the PC.</p>
<p>Save</p> 	<p>Save the message template on the PC.</p>
<p>Export to .tiff files</p> 	<p>Export the message template as a .tiff file.</p>
<p>Delete</p> 	<p>Delete the selected object.</p>
<p>Cut</p> 	<p>Cut the selected object.</p>
<p>Copy</p> 	<p>Copy the selected object.</p>

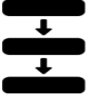



DESCRIPTION

<p>Paste</p> 	<p>Paste an object.</p>
<p>Select Tool</p> 	<p>Select and edit individual objects in the message template.</p>
<p>Hand Pan</p> 	<p>Move the designing area to the left or right.</p>
<p>Shapes</p> 	<p>Insert Lines, Rectangles, Squares, Circles and Ovals into the message template design.</p>
<p>Static Text</p> 	<p>Insert static text and barcodes into the message template design.</p>
<p>Serial Number</p> 	<p>Insert a serial number or counter into the message template design.</p>
<p>Shift Code</p> 	<p>Insert a shift code into the message template design.</p>
<p>Image</p> 	<p>Insert an image or logo into the message template design.</p>

DESCRIPTION

Tool Menu



The *Tool* menu contains the following items:

<p>Purge</p> 	<p>Purge the print head, to clear blocked nozzles.</p>
<p>Ink Cost</p> 	<p>Calculate the ink cost.</p>
<p>Event Log</p> 	<p>View the printer's event log.</p>
<p>Convert Logo</p> 	<p>Convert a logo to a format which is compatible with the G20i.</p>



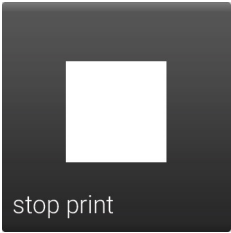

Android Device Interface

To connect the G20i to an Android device, see [“Android Device Connection” on page 6-20](#).

When starting the Domino Printer G20i Android application, the following items will be displayed:

<p>start print</p> 	<p>Start printing.</p>
<p>stop print</p> 	<p>Stop printing.</p>
<p>messages</p> 	<p>Open, edit, design, and save messages.</p>

DESCRIPTION

<p>printer settings</p> 	<p>View and change printer settings:</p> <ul style="list-style-type: none"> • density • resolution • print direction • print mode • roll over hour • print speed • print delay • print side • sensor • purge • cartridge • system clock • unit • rotate • coder name
<p>printers</p> 	<p>View and select printers with active Bluetooth connections.</p>
<p>logo</p> 	<p>View the following items:</p> <ul style="list-style-type: none"> • Generate barcodes • Create text logos • Update logos
<p>purge</p> 	<p>Purge the print head, to clear blocked nozzles.</p>

DESCRIPTION

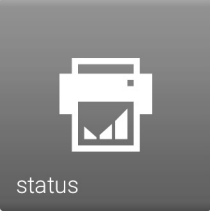
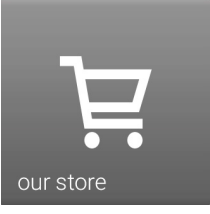
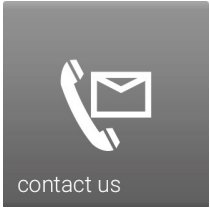
<p>status</p>  <p>The icon shows a printer with a document being printed, set against a dark grey background with the word 'status' written below it.</p>	<p>View the following printer status items:</p> <ul style="list-style-type: none"> • Printed pages • Speed • Density • Resolution • Delay before • Delay after • Ink level • Print side mode • Side on cartridge • Print mode • Repeat times • Repeat delay • Continuous delay • Auto change after • Printer name • Firmware
<p>settings</p>  <p>The icon shows a gear with a globe inside, set against a dark grey background with the word 'settings' written below it.</p>	<p>View the following items:</p> <ul style="list-style-type: none"> • Language • quick guide • about
<p>our store</p>  <p>The icon shows a shopping cart, set against a dark grey background with the words 'our store' written below it.</p>	<p>Go to the online store.</p>
<p>contact us</p>  <p>The icon shows a telephone handset and an envelope, set against a dark grey background with the words 'contact us' written below it.</p>	<p>Contact the Domino technical support team.</p>

PART 3 : OPERATION

CONTENTS

	Page
START UP	3-5
Using the Wireless USB Keyboard	3-5
Using a PC	3-6
Using an Android Device	3-8
SHUT DOWN	3-10
Using the Wireless USB Keyboard	3-10
Using a PC	3-11
Using an Android Device	3-12
START PRINTING	3-13
Using the Wireless USB Keyboard	3-13
Using a PC	3-13
Using an Android Device	3-13
STOP PRINTING	3-14
Using the Wireless USB Keyboard	3-14
Using a PC	3-14
Using an Android Device	3-14
LOADING AND PRINTING A MESSAGE	3-15
Using the Wireless USB Keyboard	3-15
Using a PC	3-16
Using an Android Device	3-17
CREATING A MESSAGE	3-18
Creating a Message Using the Wireless USB Keyboard	3-18
Barcode	3-19
Dynamic Barcode	3-20
Symbol.....	3-21
Logo.....	3-22
Single Counter	3-23
Box/Lot Counter	3-24
Date	3-26
Expiry Date	3-27

OPERATION

Time	3-28
String.....	3-29
Custom String (Chinese and Special Character Text)	3-30
Shift Code	3-31
Creating a Message Using a PC	3-32
Static Text.....	3-33
Barcode.....	3-34
Dynamic Barcode.....	3-37
Shapes	3-39
Image	3-40
Serial Number	3-41
Date / Time.....	3-43
Expiry Date.....	3-44
Shift Code	3-45
Creating a Message Using an Android Device	3-46
Static Text	3-46
Texting Logo (Chinese and Special Character Text).....	3-47
Barcode.....	3-48
Dynamic Barcode.....	3-49
Time	3-51
Date.....	3-52
Expiry Date.....	3-53
Single Counter	3-54
Box/Lot Counter.....	3-55
Shift Code	3-56
Logo	3-57
OPENING AND EDITING A MESSAGE	3-58
Using the Wireless USB Keyboard	3-58
Using a PC	3-59
Using an Android Device	3-60
EDITING A MESSAGE FIELD	3-61
Using the Wireless USB Keyboard	3-61
Using a PC	3-61

OPERATION

Using an Android Device	3-61
DELETING A MESSAGE FIELD	3-62
Using the Wireless USB Keyboard	3-62
Using a PC	3-62
Using an Android Device	3-62
COPYING A MESSAGE FIELD	3-63
Using the Wireless USB Keyboard	3-63
Using a PC	3-63
Using an Android Device	3-63
SAVING A MESSAGE	3-64
Using the Wireless USB Keyboard	3-64
Using a PC	3-64
DELETING A MESSAGE	3-65
Using the Wireless USB Keyboard	3-65
Using a PC	3-65
UPDATING LOGOS	3-66
Using the Wireless USB Keyboard and PC	3-66
Convert Logo	3-66
Update Logos	3-68
Using an Android Device	3-69
UPDATE AND CREATE STRINGS	3-70
UPDATE AND CREATE CUSTOM STRINGS	3-71
UPDATE FONTS	3-73

OPERATION

THIS PAGE INTENTIONALLY LEFT BLANK

START UP

Using the Wireless USB Keyboard



WARNING: Eye protection must be worn.

To start up the G20i using the wireless USB keyboard:

- (1) Insert the USB keyboard receiver into the USB keyboard slot on the G20i.



- (2) Turn the keyboard on, using the on/off switch on the back of the keyboard.



- (3) Insert an ink cartridge into the G20i. See [“Ink Cartridge Installation”](#) on page 6-14.

Using a PC



WARNING: Eye protection must be worn.

To start up the G20i using a PC:

- (1) Connect the PC to the G20i's USB PC socket using a USB A-B cable.

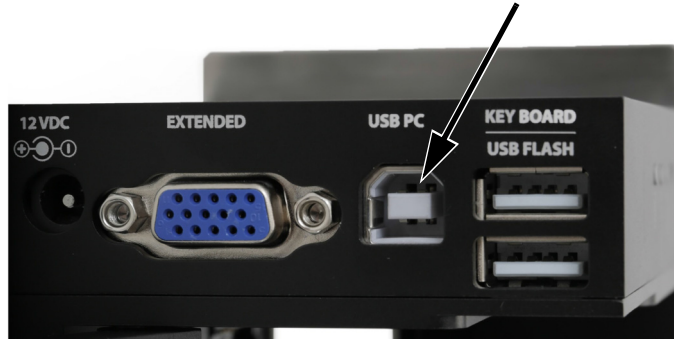

- (2) Turn the PC on.
- (3) Insert the USB keyboard receiver into the USB keyboard slot on the G20i.



- (4) Turn the keyboard on using the On/Off switch on the back of the keyboard.



OPERATION

- (5) Insert an ink cartridge into the G20i. [See “Ink Cartridge Installation” on page 6-14.](#)
- (6) From the printer’s main menu, highlight *Operation*.
- (7) Press the *Enter* button.
- (8) Highlight *Connect PC*.
- (9) Press the *Enter* button.
- (10) On the PC, open the Domino G20i software.

Using an Android Device



WARNING: Eye protection must be worn.

To start up the printer using an Android device:

- (1) Insert the USB keyboard receiver into the USB keyboard slot on the G20i.



- (2) Turn the keyboard on using the On/Off switch on the back of the keyboard.



- (3) Insert an ink cartridge into the G20i. See [“Ink Cartridge Installation” on page 6-14](#)
- (4) From the printer’s main menu, highlight *Settings*.
- (5) Press the *Enter* button.
- (6) Highlight *Bluetooth*.
- (7) Press the *Enter* button.
- (8) Ensure that *Active* is set to *Enable*.
- (9) On the Android device, turn on Bluetooth.
- (10) Open the Domino Printer G20i application on the Android device.
- (11) Select *Printers*.
- (12) Select *Search* to find the G20i.
- (13) When the G20i is found, it’s name will appear in the Printers list.
- (14) Select the G20i’s name.

OPERATION

(15) Select *Connect*.

SHUT DOWN

Using the Wireless USB Keyboard



WARNING: Eye protection must be worn.

CAUTION: To prevent the ink cartridge from drying out it must be properly stored. See [“Ink Cartridge Storage” on page 5-3](#)

To shut down the printer using the wireless USB keyboard:

- (1) From the printer’s main menu, highlight *Operation*.
- (2) Press the *Enter* button.
- (3) Press the *Enter* button to select *Stop*.
- (4) Turn the keyboard off using the on/off switch on the back of the keyboard.



- (5) Remove the ink cartridge and replace the ink cartridge cap. See [“Ink Cartridge Storage” on page 5-3](#).

Using a PC



WARNING:

Eye protection must be worn.

CAUTION:

To prevent the ink cartridge from drying out it must be properly stored. See [“Ink Cartridge Storage” on page 5-3](#)

To shut down the printer using a PC:

- (1) Open the Domino G20i software.
- (2) Open the *Printer Control* menu.
- (3) Click on the *Stop* icon to stop printing.

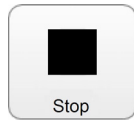

- (4) Remove the ink cartridge and replace the ink cartridge cap. See [“Ink Cartridge Storage” on page 5-3](#)

Using an Android Device



WARNING: **Eye protection must be worn.**

CAUTION: *To prevent the ink cartridge from drying out it must be properly stored. See [“Ink Cartridge Storage” on page 5-3](#)*

To shut down the printer using an Android device:

- (1) Open the G20i application on the Android device.
- (2) Select *Stop Print*.

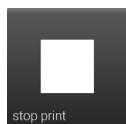

- (3) Remove the ink cartridge and replace the ink cartridge cap. See [“Ink Cartridge Storage” on page 5-3](#)

START PRINTING

Using the Wireless USB Keyboard



WARNING: Eye protection must be worn.

To start printing using the wireless USB keyboard:

- (1) From the printer's main menu, highlight *Operation*.
- (2) Press the *Enter* button.
- (3) Press the *Enter* button to select *Start*.

Using a PC



WARNING: Eye protection must be worn.

To start printing using the PC:

- (1) On the PC, open the Domino G20i software.
- (2) Open the *Printer Control* menu.
- (3) Click on the *Print* icon to start printing.



Using an Android Device



WARNING: Eye protection must be worn.

To start printing using an Android device:

- (1) Open the Domino Printer G20i application on the Android device.
- (2) Select *Start Print*.

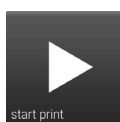

STOP PRINTING

Using the Wireless USB Keyboard



WARNING: Eye protection must be worn.

To stop printing using the wireless USB keyboard:

- (1) From the printer's main menu, highlight *Operation*.
- (2) Press the *Enter* button.
- (3) Press the *Enter* button to select *Stop*.

Using a PC



WARNING: Eye protection must be worn.

To stop printing using a PC:

- (1) Open the Domino G20i software.
- (2) Open the *Printer Control* menu.
- (3) Click on the *Stop* icon to stop printing.



Using an Android Device



WARNING: Eye protection must be worn.

To stop printing using an Android device:

- (1) Open the G20i application on the Android device.
- (2) Select *Stop Print* to stop printing.

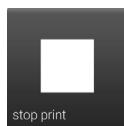

LOADING AND PRINTING A MESSAGE

Using the Wireless USB Keyboard



WARNING: **Eye protection must be worn.**

To load and print a message using the wireless USB keyboard:

- (1) From the *main menu*, highlight *Message*.
- (2) Press the *Enter* button.
- (3) Move the cursor to highlight *Open*.
- (4) Press the *Enter* button.
- (5) Highlight the message to be printed.
- (6) Press the *Enter* button.
- (7) Move the cursor to highlight *Use*.
- (8) Press the *Enter* button.
- (9) Move the cursor to highlight *Operation*.
- (10) Press the *Enter* button.
- (11) Move the cursor to highlight *Start*.
- (12) Press the *Enter* button.

Using a PC



WARNING: **Eye protection must be worn.**

Note: *When using a PC, messages will be saved locally on the PC's hard drive. If the G20i is disconnected from the PC, the message will no longer be available to the G20i for printing.*

To load and print a message using a PC:

- (1) Open the Domino G20i software.
- (2) Open the *Designing* menu.
- (3) Click on the *Open* icon.



- (4) Navigate to the location of the saved message file and select it.
- (5) Click on *Open*.
- (6) A window will open to inform you if the message has been successfully opened, click *OK* to continue.
- (7) Open the *Printer Control* menu.
- (8) Click on the *Print* icon to begin printing the message.



Using an Android Device



WARNING: **Eye protection must be worn.**

Note: *When using an Android device, only recent messages created on the Android device are available for message selection.*

To load and print a message using an Android device:

- (1) Open the *G20i Application* on the Android device.
- (2) Select *Messages*.
- (3) Select a message from the *Messages recent* list.
- (4) Select *send*.

CREATING A MESSAGE

Creating a Message Using the Wireless USB Keyboard

Note: To insert Chinese or other special characters into the message, a custom string must be used. See “[Custom String \(Chinese and Special Character Text\)](#)” on page 3-30.

To create a message using the wireless USB keyboard:

- (1) From the printer’s main menu, move the cursor to highlight *Message*.
- (2) Press the *Enter* button.
- (3) Move the cursor to highlight *Create new*.
- (4) Press the *Enter* button.
- (5) Highlight *Normal font* or *Uppercase font*.
- (6) Press the *Enter* button.
- (7) Highlight the required font size and number of lines.

Font Size	Lines
12.7 mm (0.50")	1
5.92 mm (0.23")	2
3.83 mm (0.17")	3
2.54 mm (0.10")	4
1.69mm (0.07")	6

- (8) Press the *Enter* button.
- (9) The keyboard can now be used to enter static text. Or, press the *Insert* button to enter other types of data into the message design.

Barcode

To ensure consistent barcode quality is maintained, a shaft encoder should be used to measure the production line speed. See [“Shaft Encoder Connection” on page 6-27](#).

To insert a barcode into the message design:

- (1) Whilst creating a new message, place the cursor where the barcode is required.

Note: If printing multiple lines of text, position the cursor on the bottom line. This ensures that the barcode will be fully printed.

- (2) Press the *Insert* button on the keyboard.
- (3) Move the cursor to highlight *Barcode*.
- (4) Press the *Enter* button
- (5) Move the cursor to highlight *Static*.
- (6) Press the *Enter* button.
- (7) Input the required settings:

Setting Name	Explanation
Type	Select the barcode type: <ul style="list-style-type: none"> • CODE 39 • CODE 2/5 • CODE 128 • CODE 93 • UPC-A • EAN • CODABAR • CODE 11
Width	Select the barcode width. Range: 1 - 4
Height	Select the barcode height. Range: 1 - 3
Text	<i>Enable or Disable</i> human readable text.
Value	Enter the barcode data.

- (8) Press the *Enter* button.

Dynamic Barcode

A dynamic barcode contains a counter in the barcode value.

To insert a dynamic barcode into the message design:

- (1) Whilst creating a new message, place the cursor where the dynamic barcode is required.

Note: If printing multiple lines of text, position the cursor on the bottom line. This ensures that the barcode will be fully printed.

- (2) Press the *Insert* button on the keyboard.
- (3) Move the cursor to highlight *Barcode*.
- (4) Press the *Enter* button.
- (5) Move the cursor to highlight *Dynamic*.
- (6) Press the *Enter* button.
- (7) Input the required settings:

Setting Name	Explanation
Type	Select the barcode type: <ul style="list-style-type: none"> • CODE 39 • CODE 2/5 • CODE 128 • CODE 93 • UPC-A • EAN • CODABAR • CODE 11
Width	Select the barcode width. Range: 1 - 4
Height	Select the barcode height. Range: 1 - 4
Text	Enable or Disable human readable text.
Prefix	Add text which will appear at the beginning of the dynamic barcode value.
Counter	Enter values for the counter which will be used in the barcode.
Suffix	Enter static text which will appear after the counter in the barcode.

- (8) Press the *Enter* button.

OPERATION

Symbol

The symbols shown in the table below can be added to the message as static text using the keyboard:

!	“	#	\$	%	‘	()	*	+	,	-	.	/	:	;	<
=	>	?	@	[\]	^	_	`	{		}	~			

Additional symbols, shown in the table below, can be added to the message by inserting a symbol:

€	,	f	„	...	†	‡	^	‰	<	‘	’	“	”	•	-	—
~	™	>	ı	?	£	¤	¥	¦	§	¨	©	ª	«	¬	®	¯
°	±	²	³	´	µ	¶	·	¸	¹	º	»	¼	½	¾	¿	×
Ø	P	÷	ø	þ	á	é	í	ó	ú	ü	ñ	à	À	Á	ã	Ã
ç	Ç	É	ê	Ê	Í	Ó	Ú	Ü	ä	å	æ	ë	ü	ß	ÿ	Ä
Å	Æ	Ë	Ö	â	è	î	ï	ô	œ	ù	û	Â	È	Ï	Ë	Ô
Œ	Ù	Û	ÿ	«	»											

To insert a symbol into the message design:

- (1) Whilst creating a new message, place the cursor where the symbol should appear.
- (2) Press the *Insert* button on the keyboard.
- (3) Move the cursor to highlight *Symbol*.
- (4) Press the *Enter* button.
- (5) Move the cursor to highlight the required symbol.
- (6) Press the *Enter* button.

Logo

Up to 4 logos can be saved in the printer's internal memory and made available to insert in a message design.

To update the 4 saved logos: [See "Updating Logos" on page 3-66.](#)

To insert a logo into the message design:

- (1) Whilst creating a new message, place the cursor where the logo should appear.

Note: If printing multiple lines of text, position the cursor on the bottom line. This ensures that the logo will be fully printed.

- (2) Press the *Insert* button on the keyboard.
- (3) Move the cursor to highlight *Logo*.
- (4) Press the *Enter* button.
- (5) Move the cursor to highlight the desired logo.
- (6) Press the *Enter* button.

Single Counter

Up to 6 different counters can be inserted into one message.

In the event of a power failure, when power is restored the counter will restart from the point of shutdown.

To insert a single counter into the message design:

- (1) Whilst creating a new message, place the cursor where the counter should appear.
- (2) Press the *Insert* button on the keyboard.
- (3) Move the cursor to highlight *Counter*.
- (4) Press the *Enter* button.
- (5) Move the cursor to highlight *Single*.
- (6) Press the *Enter* button.
- (7) The following counter settings can now be defined:

Notes: (1) Use the arrow keys to move the cursor to the desired setting, and enter a new value.

(2) Press the Enter button after each setting has been changed to apply the new value.

Setting Name	Explanation
Start	Enter the starting value of the counter.
Current	The current value of the counter.
Reset	Enter the reset value for the counter. When the counter reaches this value it will return to the start value. The maximum reset value is: 2,000,000,000.
Step	Enter the number of steps the counter should count in. For example, if the Step value is set to 5, the counter will count in the sequence: 5, 10, 15, 20, etc. The maximum step value is: 250.
Up/Down	Select the counting direction, either <i>Up</i> or <i>Down</i> .
Fill Zero	Add leading zeros to the start of the counter.

- (8) Highlight *Add counter here*.
- (9) Press the *Enter* button.

Box/Lot Counter

A box/lot counter is a dual counter which can be used to print box and lot numbers.

In the event of a power failure, the box/lot counter will continue counting from the same value when power is restored.

To insert a box/lot counter into the message design:

- (1) Whilst creating a new message, place the cursor where the box/lot counter should appear.
- (2) Press the *Insert* button on the keyboard.
- (3) Move the cursor to highlight *Counter*.
- (4) Press the *Enter* button.
- (5) Move the cursor to highlight *Box/Lot*.
- (6) Press the *Enter* button.
- (7) Move the cursor to highlight *Counter1*.
- (8) Press the *Enter* button.
- (9) The following settings for the first half of the Box/Lot counter can now be defined:

Notes: (1) Use the arrow keys to move the cursor to the desired setting and enter a new value.

- (2) *Press the Enter button after each setting has been changed to apply the new value.*

Setting Name	Explanation
Start	Enter the starting value of the counter.
Current	The current value of the counter.
Reset	Enter the reset value for the counter. When the counter reaches this value it will return to the start value. The maximum reset value is: 2,000,000,000.
Step	Enter the number of steps the counter should count in. For example, if the Step value is set to 5, the counter will count in the sequence: 5, 10, 15, 20, etc. The maximum step value is: 250.
Up/Down	Select the counting direction, either <i>Up</i> or <i>Down</i> .
Fill Zero	Add leading zeros to the start of the counter.

- (10) Highlight *Add counter here*.

OPERATION

- (11) Press the *Enter* button.
- (12) Press the *Insert* button on the keyboard.
- (13) Move the cursor to highlight *Counter*.
- (14) Press the *Enter* button.
- (15) Move the cursor to highlight *Box/Lot*.
- (16) Press the *Enter* button.
- (17) Move the cursor to highlight *Counter2*.
- (18) Press the *Enter* button.
- (19) The settings for the second half of the Box/Lot counter can now be defined.
- (20) Highlight *Add counter here*.
- (21) Press the *Enter* button.

Date

Note: The printer's system clock must be set up to print an accurate date value. See ["Set The System Clock" on page 6-33](#).

To insert today's date into the message design:

- (1) Whilst creating a new message, place the cursor where the date should appear.
- (2) Press the *Insert* button on the keyboard.
- (3) Move the cursor to highlight *Date*.
- (4) Press the *Enter* button.
- (5) Input the required date format into the *Format* text box:

Date Format	Explanation
d or D	The day of the month, from 1 to 31.
dd or DD	The day of the month, from 01 to 31.
M	The month, from 1 to 12.
MM	The month, from 01 to 12.
MMM	The abbreviated name of the month. Example: Jan, Feb, Mar etc
YY	The year, from 00 to 99.
YYYY	The year as a four digit number.
JJJ	The date as a 3 digit Julian number. Example: January 1st = 001
/ - . SPACE	Date separators.

- (6) Press the *Enter* button to confirm the date format.

Expiry Date

Note: The printer's system clock must be set up to print an accurate expiry date value. See ["Set The System Clock" on page 6-33](#)

To insert an expiry date into the message design:

- (1) Whilst creating a new message, place the cursor where the expiry date should appear.
- (2) Press the *Insert* button on the keyboard.
- (3) Move the cursor to highlight *Expired*.
- (4) Press the *Enter* button.
- (5) Input the required date format into the *Format* text box:

Date Format	Explanation
d or D	The day of the month, from 1 to 31.
dd or DD	The day of the month, from 01 to 31.
M	The month, from 1 to 12.
MM	The month, from 01 to 12.
MMM	The abbreviated name of the month. Example: Jan, Feb, Mar etc
YY	The year, from 00 to 99.
YYYY	The year as a four digit number.
JJJ	The date as a 3 digit Julian number. Example: January 1st = 001
/ - . _ SPACE	Date separators.

- (6) Move the cursor to highlight the *Expired* value.
- (7) Enter the number of days from the date of production to the date of expiry.
- (8) Press the *Enter* button.

Time

Note: The printer's system clock must be set up to print an accurate time value. See ["Set The System Clock" on page 6-33](#).

To insert the current time into the message design:

- (1) Whilst creating a new message, place the cursor where the time should appear.
- (2) Press the *Insert* button on the keyboard.
- (3) Move the cursor to highlight *Time*.
- (4) Press the *Enter* button.
- (5) Input the required time format into the *Format* text box:

Time format character	Explanation
s or ss	To show the seconds from 0 to 59.
m or mm	To show the minutes from 0 to 59.
h	To show the hours from 1 to 12.
hh	To show the hours from 01 to 12.
H	To show the hours from 1 to 24.
HH	To show the hours from 01 to 24.
tt	To show AM or PM.

- (6) Press the *Enter* button.

String

A string, is a string of text which has been saved in the printer's internal memory and can be inserted into a message design.

Up to 5 strings can be created and saved in the printer's internal memory.

Strings can contain up to 50 characters.

Note: To create and update strings: See ["Update and Create Strings" on page 3-70.](#)

To insert a string into the message design:

- (1) Whilst creating a new message, place the cursor where the string should appear.
- (2) Press the *Insert* button on the keyboard.
- (3) Move the cursor to highlight *String*.
- (4) Press the *Enter* button.
- (5) Move the cursor to highlight the required string.
- (6) Press the *Enter* button.

Custom String (Chinese and Special Character Text)

A custom string, is a string of text which can contain Chinese and other special characters. After a custom string has been created and saved, it can be selected and inserted into a message design.

Up to 20 custom strings can be saved in the printers internal memory.

Note: To create and update custom strings: [See “Update and Create Custom Strings” on page 3-71.](#)

To insert a custom string into the message design:

- (1) Whilst creating a new message, place the cursor where the custom string should appear.
- (2) Press the *Insert* button on the keyboard.
- (3) Move the cursor to highlight *Custom string*.
- (4) Press the *Enter* button.
- (5) Move the cursor to highlight the required custom string.
- (6) Press the *Enter* button.

Shift Code

To insert a shift code into the message design:

- (1) Whilst creating a new message, place the cursor where the shift code should appear.
- (2) Press the *Insert* button on the keyboard.
- (3) Move the cursor to highlight *Shiftcode*.
- (4) Press the *Enter* button.
- (5) Input the required settings:

Setting Name	Explanation
Code	Enter the name of the shift. Maximum 2 characters.
Time	Enter the start time of the shift.

- (6) Press the *Enter* button.

Creating a Message Using a PC

Note: The PC and G20i must remain connected to print messages created on the PC. This is because messages created on the PC are stored on the PC's hard drive.

To create a new message using a PC:

- (1) Open the Domino G20i software on the PC.
- (2) Click on the *Designing* menu on the task bar.
- (3) Click on the *New Template* icon.



- (4) The following message template settings must be defined:

Setting Name	Explanation
Name	Enter a name to identify the message template.
Width	Enter the Width of the message. The drop-down box can be used to change the unit of measurement between Centimetres, Millimetres, Inches or Pixels.
Height	Enter the Height of the message. The drop-down box can be used to change the unit of measurement between Centimetres, Millimetres, Inches or Pixels.
Show Gridlines	Tick the <i>Show Gridlines</i> tick box, to show gridlines in the message template designing window.

- (5) Click *OK*.

Static Text

To insert a static text field into the message design:

- (1) Click on the *Static Text* icon.



- (2) In the designing area, click where the static text should be placed.
- (3) The *Static Text* design window will now open, the following settings can be defined:

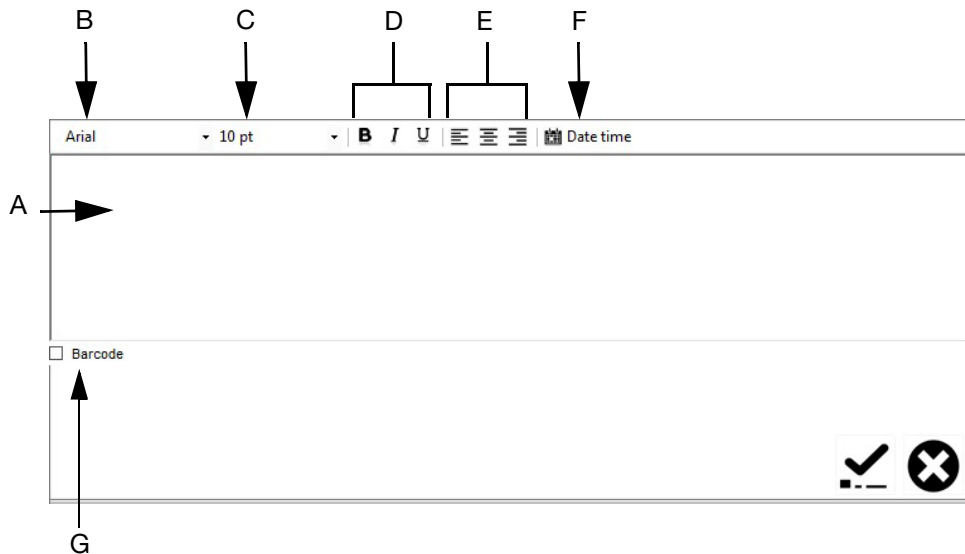

Static Text Design Window

	Explanation
A	Static text data entry area.
B	Select the font type.
C	Select the font size.
D	Select either <i>Bold</i> , <i>Italic</i> or <i>Underlined</i> font.
E	Horizontal text alignment.
F	Settings to add a <i>Date</i> , <i>Time</i> or <i>Expiry Date</i> .
G	Tick the <i>Barcode</i> tick box to convert the static text data into a barcode. See "Barcode" on page 3-34.

- (4) Click on the *Tick* icon to confirm the settings.

Barcode

To ensure consistent barcode quality is maintained, a shaft encoder should be used to measure the production line speed. See [“Shaft Encoder Connection” on page 6-27](#).

To insert a barcode into the message design:

- (1) Click on the *Static Text* icon.



- (2) Click in the message design area where the barcode is required, to open the *Static Text* window.
- (3) Click in the static text design area and enter the barcode data.
- (4) Tick the *Barcode* checkbox.
- (5) The *Barcode* window will now open. Use the *Barcode type* drop-down menu to select one of the available barcode types:

Barcode Types		
Australian Post Customer	Australian Post Customer 2	Australian Post Customer 3
Australian Post Redirection	Australian Post Reply Paid	Australian Post Routing
Aztec	Brazilian CEPNet	CODABAR 2 Widths
CODEBLOCK F	CODE 11	CODE 128
CODE 128 Subset A	CODE 128 Subset B	CODE 128 Subset C
CODE 2 OF 5 DataLogic	CODE 2 OF 5 IATA	CODE 2 OF 5 Industry
CODE 2 OF 5 Interleaved	CODE 2 OF 5 Matrix	CODE 2 OF 5 Standard
CODE 32	CODE 39	CODE 39 Full ASCII
CODE 93	CODE 93 Full ASCII	DAFT Code
DataMatrix	Deutsche Post Identcode	Deutsche Post Leitcode
DotCode	DPD	EAN 13
EAN 13 2 Digits	EAN 13 5 Digits	EAN 14 GTIN14
EAN 8	EAN 8 2 Digits	EAN 8 5 Digits
EAN UCC 128	FIM	Flattermarken

OPERATION

Barcode Types		
GS1 128	GS1 DataBar Expanded	GS1 DataBar Expanded Stacked
GS1 DataBar Limited	GS1 DataBar RSS14	GS1 DataBar Stacked
GS1 DataBar Stacked Omni Directional	GS1 DataBar Truncated	Han Xin
HIBC LIC 128	HIBC LIC 3Of9	HIBC LIC CODABLOCK F
HIBC LIC DataMatrix	HIBC LIC MPDF417	HIBC LIC PDF417
HIBC LIC QRCode	HIBC PAS 128	HIBC PAS 3Of9
HIBC PAS CODABLOCK F	HIBC PAS DataMatrix	HIBC PAS MPDF417
HIBC PAS PDF417	HIBC PAS QRCode	ISBN 13
ISBN 13 5 Digits	ISMN	ISSN
ISSN 2 Digits	Italian Postal 2Of5	Italian Postal 3Of9
ITF14	Japanese Postal	KIX
Korean Postal Authority	Logmars	MaxiCode
Micro PDF417	Micro QRCode	MSI
NVE18	PDF417	PDF417 Truncated
Pharma Zentralnummer 7	Pharma Zentralnummer 8	Pharmacode One Track
Pharmacode Two Track	Planet 12	Planet 14
Plessey	Plessey Bidirectional	QRCode
QRCode 2005	Reversed 1	Royal Mail 4 State RM4ScC
SSCC 18	Swedish Postal Shipment Item ID	Telepen
TelepenAlpha	UCC 128	UPC 12
UPC A	UPC A 2 Digits	UPC A 5 Digits

OPERATION

Barcode Types		
UPC E		UPC E 5 Digits
USPS Intelligent Mail	UPC E 2 Digits	USPS Postnet 10 ZIP 4 CD
USPS Postnet 11 ZIP 4 2	USPS Intelligent Mail Package	USPS Postnet 5 ZIP
USPS Postnet 6 ZIP CD	USPS Postnet 12 ZIP 4 2 CD	Vehicle Identification Number
	USPS Postnet 9 ZIP 4	

- (6) Use the settings in the *Barcode* window to define the Barcode's appearance.
- (7) Click on the *Tick* icon to confirm the settings.

Dynamic Barcode

A dynamic barcode contains a counter in the barcode value.

To insert a dynamic barcode into the message design:

- (1) Click on the *Serial Number* icon.



- (2) Click in the message design area where the dynamic barcode is required.
- (3) The *Serial Number* window will now open. Use the settings in the *Serial Number* window to define the dynamic barcode value:

Setting Name	Explanation
Increase From	For an ascending dynamic barcode value, enter the start value for dynamic barcode value to increase from.
Decrease From	For a descending dynamic barcode value, enter the start value for dynamic barcode value to decrease from.
Step	Enter the number of steps the dynamic barcode value should count in. For example, if the <i>Step</i> value is set to 5, the dynamic barcode value will count in the sequence: 5, 10, 15, 20, etc.
Repeat	Enter the number of times the dynamic barcode value should be repeated. For example, if the <i>Repeat</i> value is set to 5, the dynamic barcode value will count in the sequence: 11111, 22222, 33333, 44444, etc.
Reset	Enter the reset value for the dynamic barcode value. When the dynamic barcode value reaches the reset value it will reset back to the <i>Increase From</i> or <i>Decrease From</i> value.
Font	Select the font for the human readable text.
Size	Select the font size for the human readable text.
Minimum Number Length	Tick the <i>Minimum Number Length</i> tick box to specify a minimum length for the dynamic barcode value.

OPERATION

Setting Name	Explanation
Add zero to lead	Add leading zeros to the beginning of the dynamic barcode value.
Add space to lead	Add leading spaces to the beginning of the dynamic barcode value.
Prefix	Add text which will appear at the beginning of the dynamic barcode value.
Suffix	Add text which will appear at the end of the dynamic barcode value.

- (4) Tick the *Barcode* tick box.
- (5) The *Barcode* window will now open. Use the settings in the *Barcode* window to define the barcode type and appearance.
- (6) Click on the *Tick* icon to confirm the settings.

Shapes

To insert a shape into the message design:

- (1) Click on the *Shape* icon.

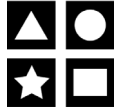

- (2) Select either a *Line*, *Rectangle*, *Square*, *Circle* or *Oval*.
- (3) Click in the message design area where the shape is required.
- (4) Left-click on the shape to resize or drag the shape to a different position.
- (5) Double-click on the shape to change the shape's properties.
- (6) Select the *Tick* icon to confirm the settings and return to the *Designing* screen.

Image

To insert an image into the message design:

- (1) Click on the *Image* icon.



- (2) Click in the message design area where the image is required.
- (3) Select the  icon to search for, and select the required image file.
- (4) Adjust the *Threshold* value and select *Preview*, until the quality of the converted image is acceptable.
- (5) Select the *Tick* icon to confirm the settings and return to the designing screen.

Serial Number

To insert a serial number into the message design:

- (1) Click on the *Serial Number* icon.

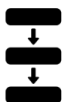

- (2) Click in the message design area where the serial number is required.
- (3) The *Serial Number* window will now open. Use the settings in the *Serial Number* window to define the serial number value:

Setting Name	Explanation
Increase From	For an ascending serial number, enter the start value for serial number to increase from.
Decrease From	For a descending serial number, enter the start value for serial number to decrease from.
Step	Enter the number of steps the serial number should count in. For example, if the <i>Step</i> value is set to 5, the serial number will count in the sequence: 5, 10, 15, 20, etc.
Repeat	Enter the number of times the serial number should be repeated. For example, if the <i>Repeat</i> value is set to 5, the serial number will count in the sequence: 11111, 22222, 33333, 44444, etc.
Reset	Enter the reset value for the serial number. When the serial number reaches this value, it will reset back to either the <i>Increase From</i> or <i>Decrease From</i> value.
Font	Select the font type.
Size	Select the font size.
Minimum Number Length	Tick the <i>Minimum Number Length</i> tick box, to define the minimum number of characters for the serial number.

OPERATION

Setting Name	Explanation
Add zeros to lead	Add leading zeros to the beginning of the serial number.
Add spaces to lead	Add leading spaces to the beginning of the serial number.
Prefix	Add text which will appear at the beginning of the serial number.
Suffix	Add text which will appear at the end of the serial number.

- (4) Select the *Tick* icon to confirm the settings and return to the designing screen.

Date / Time

Note: The printer's system clock must be set up to print an accurate date / time value. See ["Set The System Clock" on page 6-33](#).

To insert today's date, or the current time into the message design:

- (1) Click on the *Static Text* icon.



- (2) In the designing area, click where the date or time should be placed.
- (3) Click on the *Date Time* icon.

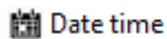

- (4) Select a date or time format, or enter a custom format into the *Custom* text box.

Note: A preview of the date or time will be shown underneath the *Example heading*.

- (5) Click *OK*.
- (6) Click on the *Tick* icon to confirm the settings.

Expiry Date

Note: The printer's system clock must be set up to print an accurate expiry date value. See ["Set The System Clock" on page 6-33](#).

To insert an expiry date into the message design:

- (1) Click on the *Static Text* icon.



- (2) In the designing area, click where the expiry date should be placed.
- (3) Click on the *Date Time* icon.

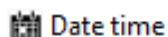

- (4) Select a date format, or enter a custom format into the *Custom* text box.

Note: A preview of the date will be shown underneath the example heading.

- (5) Enter the number of days until the expiry date, in the *Expired* text box.
- (6) Click *OK*.
- (7) Click on the *Tick* icon to confirm the settings.

Shift Code

To insert a shift code into the message design:

- (1) Click on the *Shift Code* icon.



- (2) In the designing area, click where the shift code should be placed.
- (3) The *Shift Code Options* window will now open. The font type, font size, and bold, italic or underline text can be defined on the task bar.
- (4) Enter the required shift code in each of the *Shift code* text boxes.
- (5) Enter the start time of each shift using the 24 hour clock.
- (6) Select the *Tick* icon to confirm the settings and return to the *Designing* screen.

Creating a Message Using an Android Device

To create a message using an Android device:

- (1) Open the *Domino G20i* application on the Android device.
- (2) Select *messages*.

Static Text

All 128 ASCII characters can be entered into the message as static text. To insert Chinese or other special character types using an Android device, a texting logo must be used. See [“Texting Logo \(Chinese and Special Character Text\)”](#) on page 3-47.

To insert static text into the message design:

- (1) Press *Select font type*.
- (2) Select either *Normal font* or *UPPERCASE FONT*.
- (3) Select *Select font size*.
- (4) Select a font size:

Note: A Smaller font enables more lines of text to be included in the message.

Font 1 line (12.7 mm)
Font 2 lines (5.93 mm)
Font 3 lines (3.89 mm)
Font 4 lines (2.54 mm)
Font 6 lines (1.69 mm)

- (5) Select the line where the text should appear in the message.
- (6) Use the on screen keyboard to enter the static text.

Texting Logo (Chinese and Special Character Text)

To insert Chinese or other special characters into a message using an Android device, a texting logo must be used. Up to 4 texting logos can be created and saved in the G20i.

To create, save and insert a texting logo into a message using an Android device:

- (1) Open the G20i application on the Android device.
- (2) Select *logo*.
- (3) Select *create texting logo*.
- (4) Input the required text on the *Input text in any language here* line.
- (5) Select the required font.
- (6) Adjust the *Font size of string* slider, until the font size shown in the preview is acceptable.
- (7) Select *Generate*.
- (8) Select *Yes*.
- (9) If needed, adjust the *Threshold* and *Height* sliders until the quality and height of the previewed logo is acceptable.
- (10) Select *Use this image*.
- (11) Select a logo number between 1 and 4 to save the string.
- (12) Select *Update logo*.
- (13) Return to the G20i Application's home screen.
- (14) Select *messages*.
- (15) Place the cursor where the texting logo is required.
- (16) Select the *logo* icon.
- (17) Select the required logo number.
- (18) Select *Insert*.

Barcode

To ensure consistent barcode quality is maintained, a shaft encoder should be used to measure the production line speed. See [“Shaft Encoder Connection” on page 6-27](#).

To insert a barcode into the message design:

- (1) Place the cursor where the barcode is required.

Note: If printing on multiple lines of text, position the cursor on the bottom line. This ensures that the barcode will be fully printed.

- (2) Select the *Code* icon.
- (3) Select *Static*.
- (4) The following barcode settings can be defined:

Setting Name	Explanation
Data	Enter the barcode data.
Type	Select the barcode type from the following options: <ul style="list-style-type: none"> • Code 39 • Code 2 of 5 Interleaved • Code 128 • Code 93 • Code UPC-A • Code EAN • Code Codabar • Code 11
Width	Select the barcode width. Range: 1 - 4
Height	Select the barcode height. Range: 1 - 3
Enable text	Enable or Disable human readable text.

- (5) Select *Insert* to confirm the settings and return to the Message Designer.

Dynamic Barcode

To insert a dynamic barcode into the message design:

- (1) Place the cursor where the dynamic barcode is required.

Note: If printing on multiple lines of text, position the cursor on the bottom line. This ensures that the barcode will be fully printed.

- (2) Select the *Code* icon.
- (3) Select *Dynamic*.
- (4) The following dynamic barcode settings can be defined:

Setting Name	Explanation
Data direction	Select the counting direction, either <i>Up</i> or <i>Down</i> .
Fill Zero	Enable or disable leading zeros.
Start value	Enter the start value for dynamic barcode data.
Current value	Shows the current dynamic barcode value.
Reset value	Enter the reset value for the dynamic barcode value. When the dynamic barcode value reaches the reset value it will reset back to the Start value.
Step value	Enter the number of steps the dynamic barcode value should count in. For example, if the Step value is set to 5, the dynamic barcode value will count in the sequence: 5, 10, 15, 20, etc.
Prefix value	Add text which will appear at the beginning of the dynamic barcode value.
Suffix value	Add text which will appear at the end of the dynamic barcode value.
Type	Select the barcode type from the following options: <ul style="list-style-type: none"> • Code 39 • Code 2 of 5 Interleaved • Code 128 • Code 93 • Code UPC-A • Code EAN • Code Codabar • Code 11

OPERATION

Setting Name	Explanation
Width	Select the width of the barcode from the following options: <ul style="list-style-type: none">• 1• 2• 3• 4
Height	Select the height of the barcode from the following options: <ul style="list-style-type: none">• 1• 2• 3
Enable text	Enable or Disable human readable text.

- (5) Select *Insert* to confirm the settings and return to the Message Designer.

Time

Note: The printer's system clock must be set up to print an accurate time value. See ["Set The System Clock" on page 6-33](#).

To insert the current time into the message design:

- (1) Place the cursor where the time is required.
- (2) Select the *Time* icon.
- (3) Input the time format into the text box:

Time Format	Explanation
h	The hour using a 12 hour clock from 1 to 12.
hh	The hour using a 12 hour clock from 01 to 12
H	The hour using a 24 hour clock from 0 to 23.
HH	The hour using a 24 hour clock from 00 to 23.
m	The minute from 0 to 59.
mm	The minute from 00 to 59.
s	The second from 0 to 59.
ss	The second from 00 to 59.
/ : - . _ SPACE	Time separators.
tt	AM or PM.

- (4) Select *Insert* to confirm the time format and return to the Message Designer.

Date

Note: The printer's system clock must be set up to print an accurate date value. See ["Set The System Clock" on page 6-33](#).

To insert today's date into the message design:

- (1) Place the cursor where the date is required.
- (2) Select the *Date* icon.
- (3) Select *Date*.
- (4) Input the date format into the text box:

Date Format	Explanation
d or D	The day of the month, from 1 to 31.
dd or DD	The day of the month, from 01 to 31.
M	The month, from 1 to 12.
MM	The month, from 01 to 12.
MMM	The abbreviated name of the month. Example: Jan, Feb, Mar etc
YY	The year, from 00 to 99.
YYYY	The year as a four digit number.
JJJ	The date as a 3 digit Julian number. Example: January 1st = 001
/ - . _ SPACE	Date separators.

- (5) Select *Insert* to confirm the date format and return to the Message Designer.

Expiry Date

Note: The printer's system clock must be set up to print an accurate expiry date value. See ["Set The System Clock" on page 6-33](#).

To insert an expiry date into the message design:

- (1) Place the cursor where the expiry date is required.
- (1) Select the *Date* icon.
- (2) Select *Expire date*.
- (3) Enter the number of days from the current date until the expiry date in the *Input your expire date* text box.
- (4) Enter the date format in the *Input your expire date format* text box:

Date Format	Explanation
d or D	The day of the month, from 1 to 31.
dd or DD	The day of the month, from 01 to 31.
M	The month, from 1 to 12.
MM	The month, from 01 to 12.
MMM	The abbreviated name of the month. Example: Jan, Feb, Mar etc
YY	The year, from 00 to 99.
YYYY	The year as a four digit number.
JJJ	The date as a 3 digit Julian number. Example: January 1st = 001
/ - . _ SPACE	Date separators.

- (5) Select *Insert* to confirm the expiry date format and return to the Message Designer.

Single Counter

In the event of a power failure, when power is restored the counter will restart from the point of shutdown.

To insert a counter into the message design:

- (1) Place the cursor where the counter is required.
- (2) Select the *Count* icon.
- (3) Select *Single*.
- (4) The following counter settings can be defined:

Setting Name	Explanation
Select counter number	Select the maximum number of digits in the counter from 0 to 5.
Start point	Enter the starting value for the counter.
Current point	Enter the current value for the counter.
Reset point	Enter the reset value for the counter. When the counter reaches this value it will reset to the start point value.
Count step	Enter the number of steps the counter should count in. For example, if the Count step value is set to 5, the counter will count in the sequence: 5, 10, 15, 20, etc.
Fill Zero	Turn leading zeros <i>ON</i> or <i>OFF</i> .
Direction	Select <i>Up</i> to count upwards. Select <i>Down</i> to count downwards.

- (5) Select *Insert* to confirm the settings and return to the Message Designer.

Box/Lot Counter

A box/lot counter is a dual counter which can be used to print box and lot numbers.

In the event of a power failure, when power is restored the counter will restart from the point of shutdown.

To insert a box/lot counter into the message design:

- (1) Place the cursor where the counter is required.
- (2) Select the *Count* icon.
- (3) Select *Box/Lot*.
- (4) The following counter settings can be defined:

Setting Name	Explanation
BoxLot 1	Select <i>BoxLot 1</i> to print a single box/lot counter
BoxLot 2	Select <i>BoxLot 2</i> to print two box/lot counters
Setup Counter 1 and 2	<p>The settings for each of the counters:</p> <p>First Line Enter the starting value for the counter.</p> <p>Second Line Enter the counter's current value.</p> <p>Third Line Enter the counter's reset point. When the counter reaches this number it will reset to the start point and begin counting again.</p> <p>Fourth Line Enter the number of steps the counter should count in. For example, if the <i>Step</i> value is set to 5, the counter will count in the sequence: 5, 10, 15, 20, etc.</p>
Fill Zero	Turn leading zeros <i>ON</i> or <i>OFF</i> .
Direction	Select <i>Up</i> to count upwards. Select <i>Down</i> to count downwards.

- (5) Select *Insert* to confirm the settings and return to the Message Designer.

Shift Code

To insert a shift code into the message design:

- (1) Place the cursor where the shift code is required.
- (1) Select the *Shift* icon.
- (2) 5 shift codes can be defined in the settings table:

Setting Name	Explanation
S.Code 0, 1 and 2	3 different time tables for shift codes can be defined and saved. Select either S.Code 0, 1 or 2.
1st column	Enter the name of the shift.
2nd and 3rd Column	Enter the start time of the shift.
Save shift code	Tick the <i>Save shift code</i> tick box to save the shift code when <i>Insert</i> is selected.
Load shift code	Tick the <i>Load shift code</i> tick box to load the shift code when <i>Insert</i> is selected.

- (3) Select *Insert* to confirm the settings and return to the Message Designer.

Logo

Up to 4 logos can be saved in the printer's internal memory, and made available to insert into a message design.

To update the 4 saved logos: [See "Updating Logos" on page 3-66.](#)

To insert a logo into the message design:

- (1) Place the cursor where the logo is required.
- (2) Select the *Logo* icon.
- (3) Select the Logo number from 1 to 4.
- (4) Select *Insert* to confirm the logo selection and return to the Message Designer.

OPENING AND EDITING A MESSAGE

Using the Wireless USB Keyboard

Note: It is not possible to edit a message field using the wireless USB keyboard. The message field must be deleted, and a new message field created to replace it.

To open and edit a message using the wireless USB keyboard:

- (1) From the main menu, highlight *Message*.
- (2) Press the *Enter* button.
- (3) Highlight *Open*.
- (4) Press the *Enter* button.
- (5) Highlight the message which needs to be edited.
- (6) Press the *Enter* button.
- (7) Highlight *Edit*.
- (8) Press the *Enter* button.
- (9) Use the *Arrow* buttons to move the cursor to the end of the field that needs to be edited.
- (10) Use the *backspace* button to delete the field.
- (11) Either use the keyboard to type new static text, or press the *insert* button to insert other types of data.
- (12) After the new field has been created, press the *ESC* button.
- (13) Press the *Enter* button to save the message.

Using a PC

To open and edit a message using the PC:

- (1) Start the Domino G20i software on the PC.
- (2) Open the *Designing* menu from the toolbar.
- (3) Select the *Open* icon.
- (4) Select the message which needs to be edited.
- (5) Select *Open*.
- (6) Select *OK*.
- (7) Double-click on the message field which needs to be edited.
- (8) The settings window for the selected field will now open to enable the field to be edited.
- (9) Select the *Tick* icon when you've finished editing the field and return to the Message Designer.

Using an Android Device

Notes:(1) It is only possible to open messages which were recently created on the Android device.

(2) It is not possible to edit a message field using an Android device. The message field must be deleted, and a new message field created to replace it.

To open and edit a message using an Android device:

- (1) Open the G20i application on the Android device.
- (2) Select *Messages*.
- (3) Select a message from the *Messages recent* list.
- (4) Delete the message field which requires editing.
- (5) Create a new message field to replace the deleted field.

EDITING A MESSAGE FIELD

Using the Wireless USB Keyboard

It is not possible to edit a message field using the wireless USB keyboard. The message field must be deleted, then a new message field can be created to replace it.

Using a PC

To edit a message field using the PC:

- (1) Double-click on the message field which needs to be edited.
- (2) The settings window for the selected message field will now open,
- (3) Select the *Tick* icon when you've finished editing the message field to return to the Message Designer.

Using an Android Device

It is not possible to edit a message field using an Android device. The message field must be deleted, then a new message field can be created to replace it.

DELETING A MESSAGE FIELD

Using the Wireless USB Keyboard

To delete a message field using the wireless USB keyboard:

- (1) Move the cursor to the end of the field to be deleted.
- (2) Use the backspace button on the keyboard.

Using a PC

To delete a message field using a PC:

- (1) Click on the message field to be deleted.
- (2) Either press the *Delete* button on the keyboard or click on the *Delete* icon on the task bar.



Using an Android Device

To delete a message field using an Android device:

- (1) Highlight the message field to be deleted.
- (2) Use the delete or backspace key to delete the message field.

COPYING A MESSAGE FIELD

Using the Wireless USB Keyboard

Note: This feature is not available.

Using a PC

To copy a message field using a PC:

- (1) Click on the message field to be copied.
- (2) Click on the *Copy* icon on the task bar.



- (3) Click on the *Paste* icon on the task bar.



- (4) Click on and drag the copied message field to the required position.

Using an Android Device

To copy a message field using an Android device:

- (1) Highlight the message field to be copied.
- (2) Select the *Copy* icon.
- (3) Place the cursor where you require the copied message field to be pasted.
- (4) Select the *Paste* icon.

SAVING A MESSAGE

Using the Wireless USB Keyboard

To save a message using the wireless USB keyboard:

Note: Messages created using a wireless USB keyboard will be saved in the G20i's internal memory.

- (1) Press the *ESC* button.
- (2) Highlight *Save*.
- (3) Press the *Enter* button.

Using a PC

To save a message using a PC:

Note: Messages created on the PC will be saved in the PC's hard drive.

- (1) Select the *Save Template* icon.



- (2) In the *File name* text box, enter a name for the message.
- (3) Select *Save*.

Using an Android Device

To save a message using an Android device:

Notes: (1) Messages created using an Android device can only be saved by sending the message to print.

(2) Sending a message to print will overwrite any message which the G20i is currently printing.

- (1) Select the *Send message* icon in the Message Designer.



- (2) Select *Send*.

DELETING A MESSAGE

Using the Wireless USB Keyboard

To delete a message using the wireless USB keyboard:

- (1) From the main menu, highlight *Message*.
- (2) Press the *Enter* button.
- (3) Move the cursor to highlight *Open*.
- (4) Press the *Enter* button.
- (5) Highlight the message which needs to be deleted.
- (6) Press the *Enter* button.
- (7) Move the cursor to highlight *Delete*.
- (8) Press the *Enter* button.

Using a PC

To delete a message using the wireless USB keyboard:

- (1) Open *Windows Explorer* on the PC.
- (2) Navigate to the location of the saved message file.
- (3) Select the message file.
- (4) Press the *Delete* button.

Using an Android Device

It is not possible to delete a message using an Android device.

UPDATING LOGOS

Using the Wireless USB Keyboard and PC

Convert Logo

All logos and images must be converted to a .hex format in order to be used by the printer.

Notes: (1) The Convert Logo tool accepts .BMP .JPG .GIF .TIF file formats.

(2) The image size must be 150 x 1600 pixels or less.

To convert a logo:

- (1) Open the Domino G20i software.
- (2) Open the *Tool* menu.
- (3) Click on *Convert Logo*.
- (4) Click on *Browse..*
- (5) Navigate to the location of the logo or image file and select it.
- (6) Click on *Open*.
- (7) Adjust the Threshold slider until the quality of the preview image is acceptable.

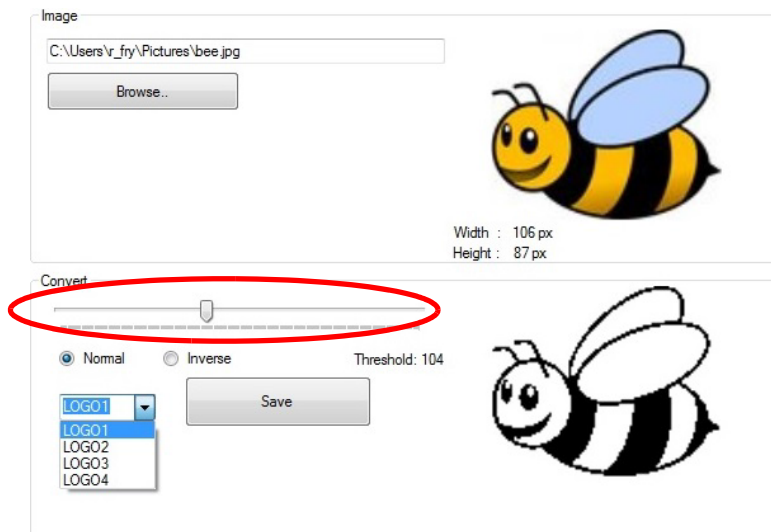

OPERATION

- (8) Choose the name of the logo, either LOGO1, LOGO2, LOGO3 or LOGO4.

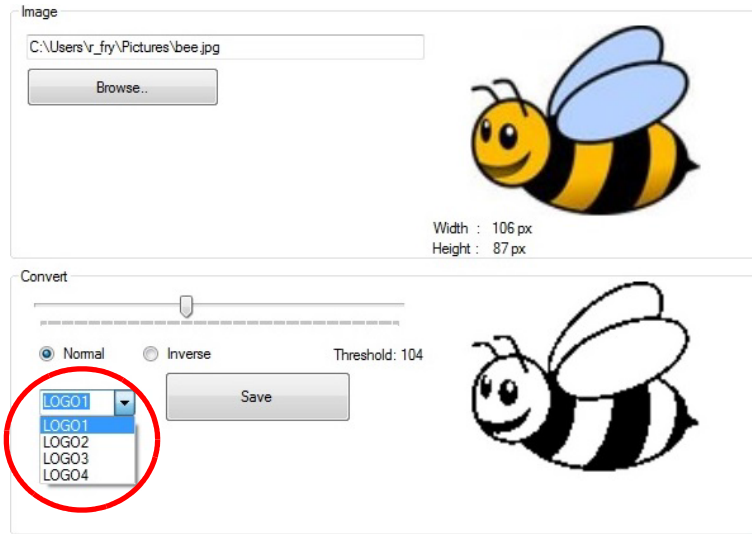

- (9) Click on *Save*.
- (10) Save the converted logo to a USB flash drive.

Update Logos

To update the logos on the printer:

- (1) Convert the logo to a format which can be used by the printer. [See “Convert Logo” on page 3-66](#)
- (2) Insert the USB flash drive which contains the logo file into the G20i's USB flash port.
- (3) From the printer's main menu, use the wireless USB keyboard to move the cursor down to highlight *Settings*.
- (4) Press the *Enter* button.
- (5) Move the cursor down to highlight *Update Logo*.
- (6) Press the *Enter* button.
- (7) Highlight the name of the logo you wish to update.
- (8) Press the *Enter* button to update the logo from the USB flash drive to the printers internal memory.
- (9) Remove the USB flash drive from the printer.
- (10) Press the *ESC* button to return to the printer's main menu.

Using an Android Device

To update a logo from an Android device:

- (1) Open the *G20i Application* on the Android device.
- (2) Select *logo*.
- (3) Select *update logo*.
- (4) Select *Choose image...*
- (5) Select the image to be used from the Android device's memory.
- (6) If needed, adjust the *Threshold, Height and Width* sliders until the quality and size of the previewed logo is acceptable.
- (7) Select *Use this image*.
- (8) Select a logo number between 1 and 4 to save the logo.
- (9) Select *Update logo*.

UPDATE AND CREATE STRINGS

Note: A wireless USB keyboard is required for this procedure.

A string, is a string of text which can be saved to the G20i and made available to insert into message designs using the wireless USB keyboard. Up to 5 strings with a maximum of 50 characters can be saved.

To insert a string into a message design: [See “String” on page 3-29.](#)

To create and update the saved strings on the G20i:

- (1) Using the wireless USB keyboard, from the printer's main menu, move the cursor down to highlight *Settings*.
- (2) Press the *Enter* button.
- (3) Move the cursor down to highlight *String*.
- (4) Press the *Enter* button.
- (5) A window will open in which 5 lines of text can be input. Each line represents a different string. Move the cursor to the string that requires updating.
- (6) Use the Backspace button to delete the string data.
- (7) Use the keyboard to enter new string data.
- (8) Press the *Enter* button.
- (9) Press the *ESC* button to return to the printer's main menu.

UPDATE AND CREATE CUSTOM STRINGS

A custom string, is a string of text which can contain Chinese and other special characters. After a custom string has been created and saved, it can be selected and inserted into a message design. Up to 20 custom strings can be saved in the printers internal memory.

To create and update a custom string:

- (1) Insert a USB flash drive into the PC's USB port.
- (2) Open the Domino G20i software.
- (3) Open the *Tool* menu.
- (4) Click on *Convert Logo*.
- (5) Click on the *String* tab.
- (6) The *String* settings window will now open, as illustrated below:

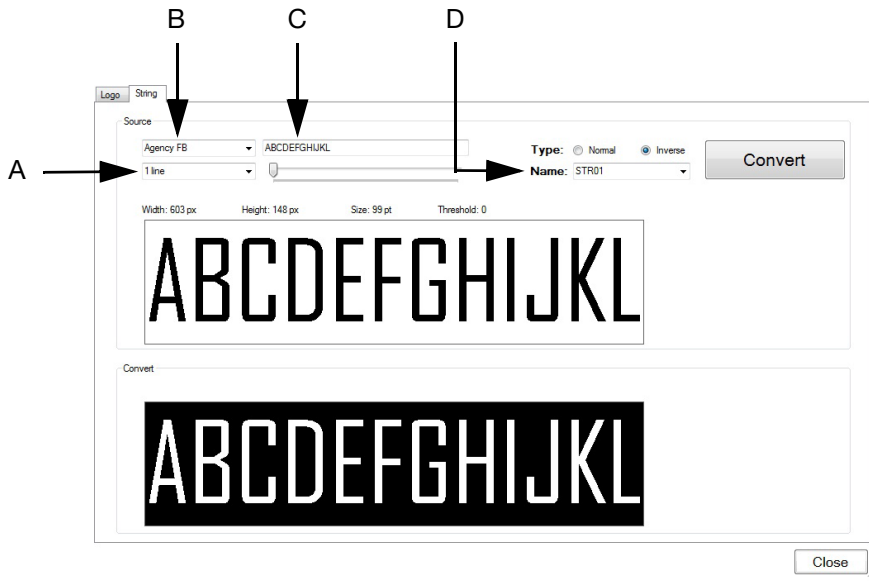

String Settings Window

A	The font size.
B	The font type.
C	The string data.
D	The string name.

- (7) After the string settings have been defined, click on *Convert* to save the string.
- (8) Navigate to the location of the USB flash disk.
- (9) Click on *OK*.
- (10) Remove the USB flash disk from the PC.

OPERATION

- (11) Insert the USB flash disk into the G20i's USB flash port.
- (12) From the printer's main menu, use the wireless USB keyboard to move the cursor down to highlight *Settings*.
- (13) Press the *Enter* button.
- (14) Move the cursor to highlight *Custom string*.
- (15) Press the *Enter* button.
- (16) Highlight the name of the custom string you wish to update.
- (17) Press the *Enter* button.
- (18) Remove the USB flash disk from the printer.
- (19) Press the *ESC* button to return to the printer's main menu.
- (20) The new custom string will now be available to insert into a message.
[See "Custom String \(Chinese and Special Character Text\)" on page 3-30.](#)

UPDATE FONTS

Note: A PC, wireless USB keyboard and a USB flash drive are required to update fonts.

The G20i can only support 1 font type for each font size when creating messages using the wireless USB keyboard or Android device. The font files are saved in the G20i's internal memory.

When creating a message using a PC, all Windows TrueType fonts can be selected.

To update the fonts stored in the G20i:

- (1) Convert the new fonts to a .hex format on a PC.
- (2) Copy the .hex font files to a USB flash disk.
- (3) Name the font files using the file names in the table below:

File Name	Font Size
FONT1.hex	12.7mm
FONT2.hex	5.93mm
FONT3.hex	3.89mm
FONT4.hex	2.54mm
FONT5.hex	1.69mm

- (4) Remove the USB flash disk from the PC.
- (5) Insert the USB flash disk into the G20i's USB flash port.
- (6) From the printer's main menu, use the wireless USB keyboard to move the cursor down to highlight *Settings*.
- (7) Press the *Enter* button.
- (8) Move the cursor to highlight *Update Font*.
- (9) Press the *Enter* button.
- (10) Move the cursor to highlight the desired font size, or highlight *All*.
- (11) Press the *Enter* button.
- (12) Remove the USB flash disk when updating is complete.

OPERATION

THIS PAGE INTENTIONALLY LEFT BLANK

PART 4 : FAULT FINDING

CONTENTS

	Page
TRUBLESHOOTING	4-3
Hardware Error Messages	4-3
Firmware Error Messages	4-3
Software Error Messages	4-3
PRINT QUALITY FAULTS	4-4

FAULT FINDING

THIS PAGE INTENTIONALLY LEFT BLANK

TROUBLESHOOTING

Hardware Error Messages

Use the table below to diagnose and solve hardware faults.

Error Message	Reason	Solution
Display no cartridge	No connection between the circuit board on the ink cartridge and the printer.	Remove the ink cartridge and insert it into the printer again. Clean the ink cartridge contacts (page 5-6).
Not print	The internal product sensor is dirty.	Clean the internal product sensor.

Firmware Error Messages

Use the table below to diagnose and solve firmware faults.

Error Message	Reason	Solution
Failure updating language and others	Miss-press F12 key.	Press the F12 key.
The printing result is not correct	A previous unknown setting has confused the printer.	Reset the G20i to factory default.









Software Error Messages

Use the table below to diagnose and solve software faults.

Error Message	Reason	Solution
Delay printing is not correct	A software programme such as an anti-virus programme has interfered with the data signal between the PC and printer.	Disable or remove the software programme which is causing interference.

PRINT QUALITY FAULTS

Use the table below to diagnose and solve print quality faults.

Problem	Example	Action
Print face too far away from the substrate.		Lower the print head until print quality is acceptable.
Print face touching the substrate.		Raise the print head until the print quality is acceptable.
Print face at an angle.		Ensure the rows of print nozzles are parallel with the leading edge of the substrate.
Print nozzles parallel with movement of substrate.		Ensure the print nozzles are perpendicular to the product movement.
Print face nozzles have become blocked.		Wipe print face or perform a purge. If the nozzles do not unblock replace the ink cartridge.
Print becomes blurred over the top or bottom of the text.		Print nozzles are perpendicular to product movement, however the print face is not parallel to the substrate.
Encoder is slipping, or internal speed setting is wrong.		Check the encoder installation. Check the speed setting.
Print too faint.		Increase the print resolution or print density.
Print too dark/ too much ink on substrate or ink consumption too high.		Decrease the print resolution or print density.

PART 5 : MAINTENANCE

CONTENTS

	Page
INK CARTRIDGE MAINTENANCE	5-3
Ink Cartridge Storage	5-3
Ink Cartridge Cleaning	5-4
Why Ink Cartridges Require Cleaning	5-4
Clean the Ink Cartridge Print Head.....	5-5
Clean the Ink Cartridge Contacts.....	5-6
Manual Nozzle Purge.....	5-7
Automatic Nozzle Purge.....	5-8
Automatic Nozzle Switching.....	5-9
UPDATE FIRMWARE	5-11
UPDATE LANGUAGES	5-12
RESET TO FACTORY DEFAULT SETTINGS	5-13

MAINTENANCE

THIS PAGE INTENTIONALLY LEFT BLANK

INK CARTRIDGE MAINTENANCE

Ink Cartridge Storage

Interruptions to the printing cycle can affect the print quality. After prolonged periods of inactivity ink will begin to evaporate and cure on the nozzle plate and in the nozzle chamber. This blocks the chamber and can either restrict the firing of the ink drops or cause them to deviate from their correct course.

Each type of ink, aqueous and ethanol based, have different De-Cap times:

For aqueous inks with short periods of inactivity, typically breaks in the printing cycle for less than 2 hours, no measures are required and the cartridge can remain in the print head.

For ethanol inks the De-Cap time can vary depending on the ink being used; typically they will require capping for between 10 to 60 minutes of inactivity during the printing cycle. For a perfect first print, wipe the nozzle face with a dry, lint-free tissue before starting operations again and/or print a couple of test messages. Purge settings can also be written into the operations, which would lessen the need for wiping.

For both types of ink, for periods of inactivity longer than stated above, the cartridge should be removed and the cap placed on the nozzles to stop the ink from drying. When starting operations for the first time after an extended break, wipe the nozzle face and print a couple of test prints before resuming.

Room temperature has an influence on the behaviour of the fluid dynamics of the ink - cartridges should always be operated within the temperature ranges as specified on the MSDS.

Ink Cartridge Cleaning

Dirty working environments can contaminate the print heads and print cartridges, affecting the quality of printed messages.

Why Ink Cartridges Require Cleaning

- Cured ink on the nozzle plate blocks or restricts firing. Ethanol and aqueous varieties both have different De-Cap times; however, during periods of inactivity without capping cartridges all varieties of ink may begin to cure on the nozzle plate.
- Environmental contaminations from of the production line (e.g. substrate fibres, dust, and ink spray) build up on the print heads and print cartridges. The result can block nozzles and block electrical contacts between the print head and cartridge.
- Abrasion on the nozzle face from particular substrates can damage nozzles and block them during the production run.

It is important to ensure that the print heads and cartridges are kept as clean as possible - free from substrate fibres, ink residue, and any other contamination that can build up during production.

Therefore it is recommended practice to clean an ink cartridge before fitting it to a print head and starting production. This ensures any dry ink residue is removed from the nozzle face before printing.

Clean the Ink Cartridge Print Head



WARNING: Eye protection must be worn.

- CAUTIONS:**
- (1) To avoid damaging the print head, do not apply excessive force.
 - (2) Do not shake or squeeze the ink cartridge.
 - (3) To avoid clogging the print head nozzles, use a lint free cloth and de-ionized water.

To clean the ink cartridge:

- (1) Moisten a lint free cloth with de-ionized water.
- (2) Gently wipe the ink cartridge across the lint free cloth.



- (3) Continue to wipe the ink cartridge across the lint free cloth until 2 solid dark lines of ink appear.

Note: Use a fresh piece of cloth each time the ink cartridge is wiped.

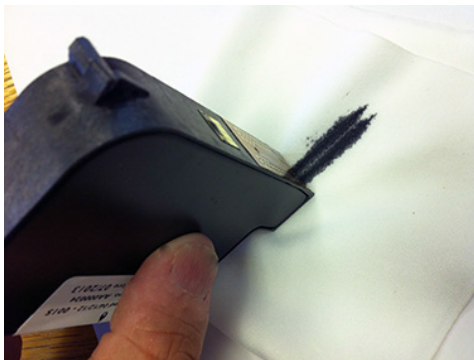

Clean the Ink Cartridge Contacts

In some instances rows of nozzles in the print head can stop firing, see the image below.

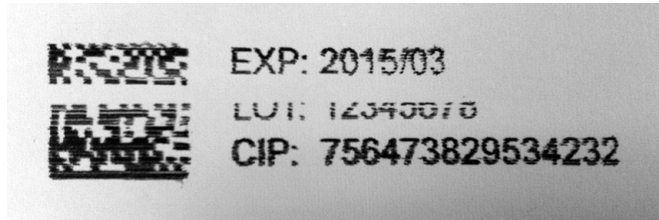

In such situations, the electrical contacts sending signals to the ink cartridge may have been impeded by contamination.

To clean the contacts:

- (1) Remove the cartridge from the print head.
- (2) Clean the gold contact foil by gently wiping a lint free cloth across the contacts.

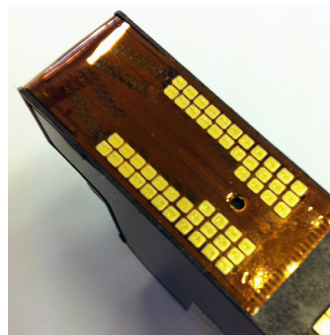

- (3) Gently clean the contacts in the printer with the lint free cloth.



Manual Nozzle Purge

If the nozzles in the print head become blocked, and cleaning the print head does not clear the blockage a purge can be carried out. A purge will force ink out of the nozzles and should clear them. If this does not clear the nozzle, the ink cartridge will need to be replaced.

Note: The printer can also be set to automatically purge the ink cartridge nozzles during periods of inactivity. See [“Automatic Nozzle Purge”](#) on page 5-8.

Using the Wireless USB Keyboard



WARNING: Eye protection must be worn.

To purge the ink cartridge using a wireless USB keyboard:

- (1) From the printer's main menu, move the cursor down to highlight *Operation*.
- (2) Press the *Enter* button.
- (3) Move the cursor down to highlight *Purge*.
- (4) Press the *Enter* button.

Using a PC



WARNING: Eye protection must be worn.

To purge the ink cartridge using a PC:

- (1) Open the Domino G20i software.
- (2) Open the *Tool* menu.
- (3) Click on *Purge*.

Using an Android Device



WARNING: Eye protection must be worn.

To purge the ink cartridge using an Android device:

- (1) Open the Domino Printer G20i application on the Android device.
- (2) Select *Purge*.

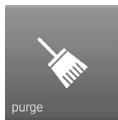

- (3) Select *purge now!*

Automatic Nozzle Purge

To prevent ink from drying in the print head nozzles during periods of inactivity; the printer can be set to automatically purge the nozzles at regular intervals.

Set up Automatic Nozzle Purge using the Wireless USB Keyboard

To set up an automatic nozzle purge using the wireless USB keyboard:

- (1) From the main menu, highlight *Settings*.
- (2) Press the *Enter* button.
- (3) Highlight *Purge*.
- (4) Press the *Enter* button.
- (5) Highlight *Status*.
- (6) Press the *Enter* button.
- (7) Highlight *Enable*.
- (8) Press the *Enter* button.
- (9) Highlight *Time*.
- (10) Enter a suitable time value (the time between nozzle purges).
- (11) Press the *Enter* button.
- (12) Press *ESC* to return to the main menu.

Set up Automatic Nozzle Purge using the PC

To set up an automatic nozzle purge using the PC:

- (1) Open the Domino G20i software.
- (2) Open the *Printer Control* menu.
- (3) In the *Print-Head* sub menu, change the *Purge Status* to *On*.
- (4) Change the *Purge Time* (the time between nozzle purges) to a suitable value.

Set up Automatic Nozzle Purge using an Android device

To set up an automatic nozzle purge using an Android device:

- (1) Open the Domino Printer G20i application on the Android device.
- (2) Select *printer settings*.
- (3) Select *purge*.
- (4) Tick the *Enable Purge* tick box.
- (5) Enter a suitable *Delay time (Seconds)* (the time between nozzle purges) value.
- (6) Return to the application's home screen.

Automatic Nozzle Switching

The print head has 2 banks of nozzles. To increase the nozzle life, rather than use both or 1 nozzle bank for every print, the G20i can alternate nozzle banks for each print.

Set up Automatic Nozzle Switching using the Wireless USB Keyboard

To set up this feature using the wireless USB keyboard:

- (1) From the main menu, highlight *Settings*.
- (2) Press the *Enter* button.
- (3) Highlight *Print Side*.
- (4) Press the *Enter* button.
- (5) Highlight *Select*.
- (6) Press the *Enter* button.
- (7) Highlight *Auto*.
- (8) Press the *Enter* button.
- (9) Highlight *Value*.
- (10) Enter the number of times 1 nozzle bank will print before switching to the second nozzle bank.
- (11) Press the *Enter* button.
- (12) Press *ESC* to return to the main menu.

Set up Automatic Nozzle Switching using the PC

Note: This feature cannot be set up using a PC when printing at 600 DPI. Both nozzle banks are required for 600 DPI printing.

To set up this feature using the PC:

- (1) Open the Domino G20i software.
- (2) Open the *Printer Control* menu.
- (3) In the *Print-Head* sub menu, change the *Switch Nozzle Auto* setting to *On*.
- (4) Change the *Times* value, to the number of times 1 nozzle bank will print before switching to the second nozzle bank.

Set up Automatic Nozzle Switching using an Android device

To set up this feature using an Android device:

- (1) Open the Domino Printer G20i application on the Android device.
- (2) Select *printer settings*.
- (3) Select *print side*.
- (4) De-select the *Manual mode* tick box.
- (5) Enter the number of times 1 nozzle bank will print before switching to the second nozzle bank in the *Auto change value* text box.
- (6) Select *OK*.

UPDATE FIRMWARE

CAUTION: Do not turn off the printer or disconnect the power supply whilst the printer firmware is being updated.

- Notes: (1) A blank USB flash drive with a capacity less than 4GB is required for this procedure.
- (2) A USB wireless keyboard will be required to control the printer for this procedure.
- (3) All data and settings saved in the printer will be lost after the firmware is updated.

To updated the printers firmware:

- (1) Download the firmware files to a PC.
- (2) Insert the USB flash drive into the PC's USB port.
- (3) Copy the new firmware file onto the USB flash drive.
- (4) Disconnect the USB flash drive from the PC.
- (5) Disconnect all of the inputs and outputs on the G20i except for the power supply and USB wireless keyboard.
- (6) Remove the ink cartridge from the G20i.
- (7) Insert the USB flash disk into the G20i's USB flash port.
- (8) From the printer's main menu, use the wireless USB keyboard to move the cursor to highlight *Settings*.
- (9) Press the *Enter* button.
- (10) Move the cursor to highlight *About*.
- (11) Press the *Enter* button.
- (12) Move the cursor to highlight *Update firmware*.
- (13) Press the *Enter* button.
- (14) Move the cursor to highlight *Yes*.
- (15) Press the *Enter* button.
- (16) The update process will take up to 10 minutes to complete.
- (17) After the update is complete, press *ESC* to return to the printer's main menu.
- (18) Press the *F12* button.
- (19) If the G20i's language files need to be updated, leave the USB flash drive in the G20i and follow the Update Languages procedure on [page 5-12](#). If the language files do not need to be updated, the USB flash drive can now be disconnected from the G20i.

UPDATE LANGUAGES

Note: A USB wireless keyboard will be required to control the printer for this procedure.

To update the languages on the printer:

- (1) Update the printer's firmware. See ["Update Firmware" on page 5-11](#).
- (2) From the printer's main menu, move the cursor to highlight *Settings*.
- (3) Press the *Enter* button.
- (4) Move the cursor to highlight *Language*.
- (5) Press the *Enter* button.
- (6) Move the cursor to highlight the required language.
- (7) Press the *Enter* button.
- (8) Press the *ESC* button to return to the main menu.
- (9) Press the *F12* button.

RESET TO FACTORY DEFAULT SETTINGS

Note: A wireless USB keyboard is required for this procedure.

To reset the G20i back to the factory default settings:

- (1) From the main menu, highlight *Settings*.
- (2) Press the *Enter* button.
- (3) Move the cursor to highlight *Default*.
- (4) Press the *Enter* button.
- (5) Move the cursor to highlight *Yes*.
- (6) Press the *Enter* button.

MAINTENANCE

THIS PAGE INTENTIONALLY LEFT BLANK

PART 6 : INSTALLATION

CONTENTS

	Page
INSTALLATION	6-3
Unpacking	6-3
Pack Contents	6-3
Mounting the G20i to a Conveyor	6-8
Grounding the G20i	6-11
Power Supply Connection	6-12
Wireless USB Keyboard Connection	6-13
Ink Cartridge Installation	6-14
PC Connection and Software Installation	6-16
Disable Driver Signature Enforcement	6-18
Manual Driver Installation	6-19
Android Device Connection	6-20
INPUT CONNECTIONS	6-21
NPN Input Signal Connection	6-21
External Product Sensors	6-22
NPN Product Sensor Connection	6-22
PNP Product Sensor Connection.....	6-23
Push-pull Product Sensor Connection.....	6-24
OUTPUT CONNECTIONS	6-25
NPN Output Signal Connection	6-25
Alarm Beacon Connection	6-26
Shaft Encoder Connection	6-27
Shaft Encoder Wheel Diameter	6-28
SHAFT ENCODER SET-UP	6-29
Using the Wireless USB Keyboard	6-29
Using a PC	6-29
INTERNAL PRODUCT SENSOR	6-30
Internal Product Sensor Calibration	6-31
PRINTER SETTINGS	6-33
Set The System Clock	6-33
Using the Wireless USB Keyboard	6-33

INSTALLATION

Using a PC	6-33
Using an Android Device	6-33
Set the Unit of Measurement	6-34
Using the Wireless USB Keyboard	6-34
Using a PC	6-34
Using an Android Device	6-34
Set the Print Direction	6-35
Using the Wireless USB Keyboard	6-35
Using a PC	6-35
Using an Android Device	6-36
Set the Print Density	6-37
Using the Wireless USB Keyboard	6-37
Using a PC	6-37
Using an Android Device	6-37
Set the Print Resolution (DPI)	6-38
Using the Wireless USB Keyboard	6-38
Using a PC	6-38
Using an Android Device	6-39
Set the Print Speed	6-40
Using the Wireless USB Keyboard	6-40
Using a PC	6-40
Using an Android Device	6-41
Set the Product Sensor Type	6-42
Using the Wireless USB Keyboard	6-42
Using a PC	6-42
Using an Android Device	6-43
Set the Print Delay	6-44
Using the Wireless USB Keyboard	6-44
Using a PC	6-44
Using an Android Device	6-45
Set the Print Mode	6-46
Using the Wireless USB Keyboard	6-46
Using a PC	6-48
Using an Android Device	6-49
Set Password Protection	6-50



INSTALLATION

Unpacking





Remove the G20i and accessories from the packaging.

Check the contents of the package against the pack contents list, report any discrepancies to the supplier immediately.

Pack Contents

Quantity	Description
1	 <p data-bbox="735 1005 1082 1037"><i>G20i Thermal Inkjet Printer</i></p>
1	 <p data-bbox="815 1424 975 1456"><i>Base Clamp</i></p>
2	 <p data-bbox="860 1821 959 1852"><i>Clamps</i></p>

INSTALLATION

Quantity	Description
1	 <p data-bbox="715 622 954 658"><i>Anti Shock Clamp</i></p>
1	 <p data-bbox="678 1010 997 1046"><i>19 x 300mm Round Bar</i></p>
1	 <p data-bbox="705 1368 1023 1404"><i>19 x 200mm Round Bar</i></p>
5	 <p data-bbox="657 1749 1007 1785"><i>Hex Cap Screw 8 x 20mm</i></p>



INSTALLATION

Quantity	Description
2	 <p data-bbox="708 533 1054 566"><i>Hex Cap Screw 8 x 15mm</i></p>
3	 <p data-bbox="735 824 1082 857"><i>Hex Cap Screw 4 x 10mm</i></p>
1	 <p data-bbox="746 1205 1062 1238"><i>Wireless USB Keyboard</i></p>
1	 <p data-bbox="807 1630 1015 1664"><i>USB A-B Cable</i></p>

INSTALLATION

Quantity	Description
1	 <p data-bbox="703 748 903 786"><i>Power Adapter</i></p>
1	 <p data-bbox="624 1149 1043 1187"><i>Ground Cable with M3x5 Screw</i></p>
1	 <p data-bbox="756 1543 916 1581"><i>Screwdriver</i></p>

INSTALLATION

Quantity	Description
1	 <p data-bbox="815 618 1002 656"><i>6mm Hex Key</i></p>
1	 <p data-bbox="815 999 1002 1037"><i>3mm Hex Key</i></p>

INSTALLATION

Mounting the G20i to a Conveyor

Tools Required:

- 3mm hex key
- 6mm hex key

To mount the G20i to a conveyor:

- (1) Mount the Anti Shock Clamp to the side of the G20i.

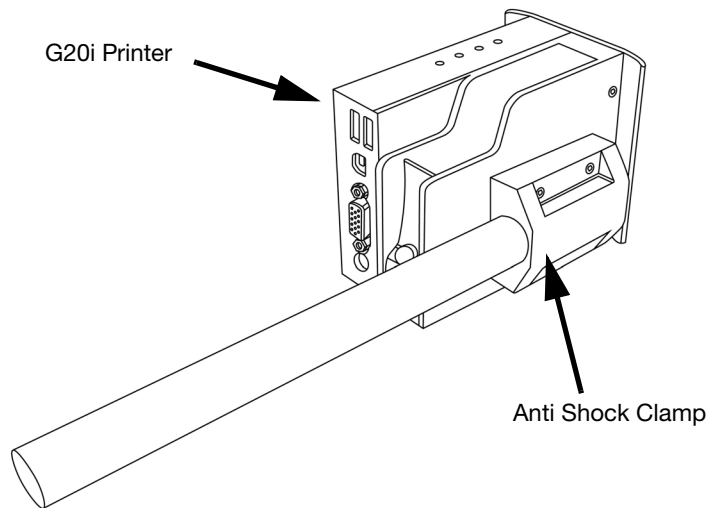

- (2) Mount the Base Clamp and 19 x 200mm Round Bar to the side of the conveyor.

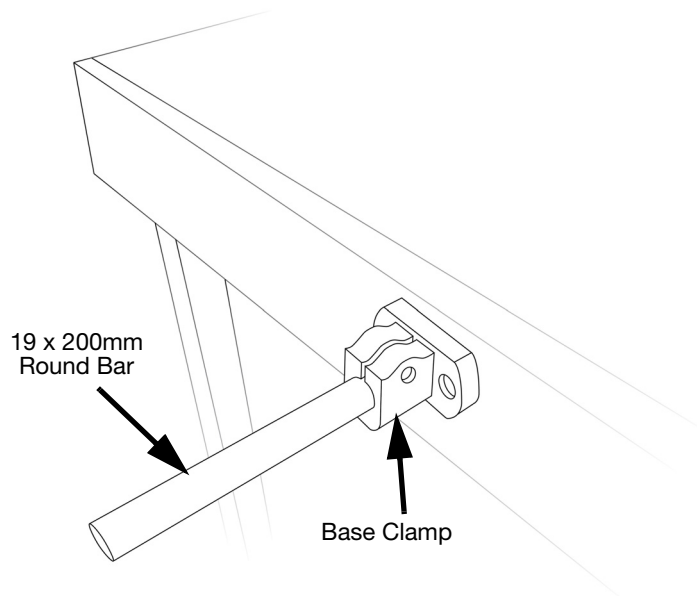

INSTALLATION

- (3) Slide the 2 Clamps onto the 19 x 300mm Round Bar.

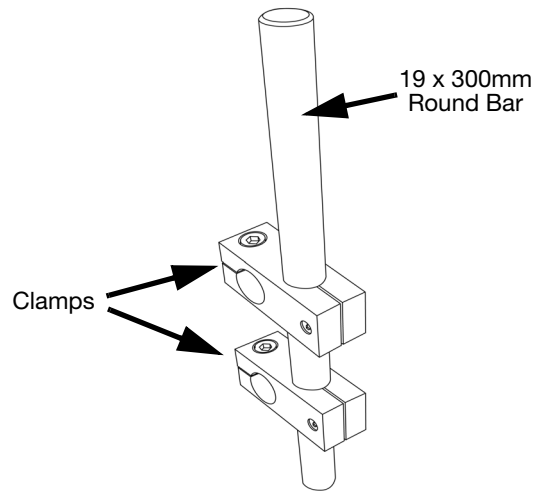

- (4) Mount the 19 x 300mm Round Bar with Clamps onto the 19 x 200mm Round bar.

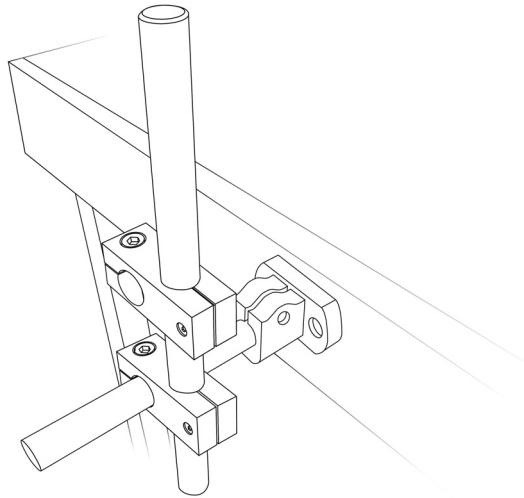

INSTALLATION

- (5) Mount the G20i and Anti Shock Clamp onto the 19 x 300mm Round Bar.

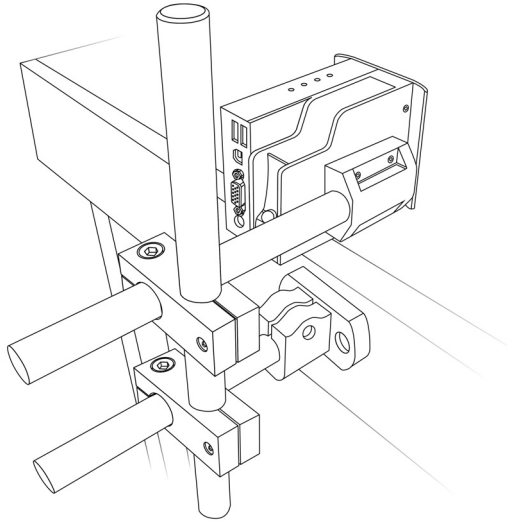

- (6) Adjust position of the printer so that it is 3mm further forwards than the conveyor guide rail.

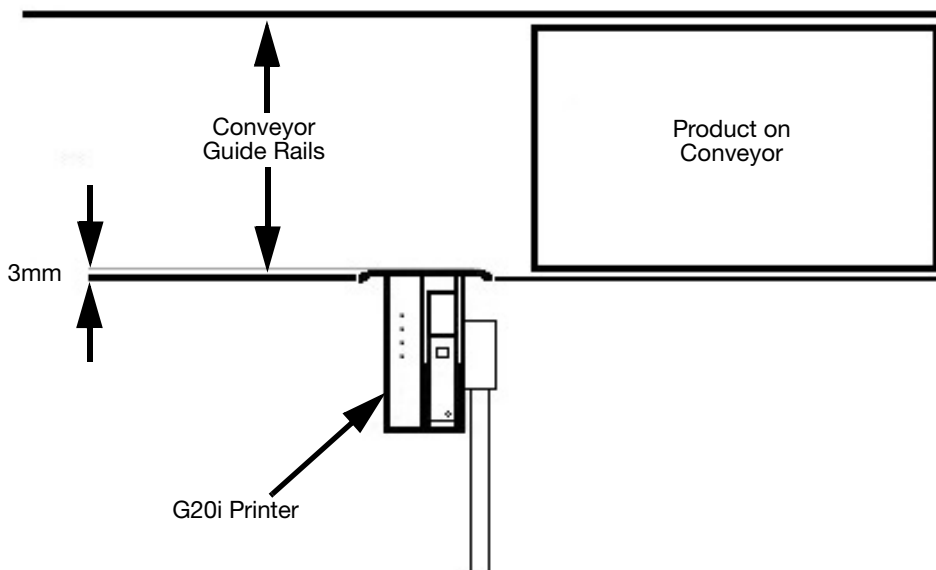

- (7) Tighten all of the screws.

Grounding the G20i

To ground the G20i:

- (1) Attach the ground cable to the ground point, on the underside of the anti shock clamp using the M3x5 screw.

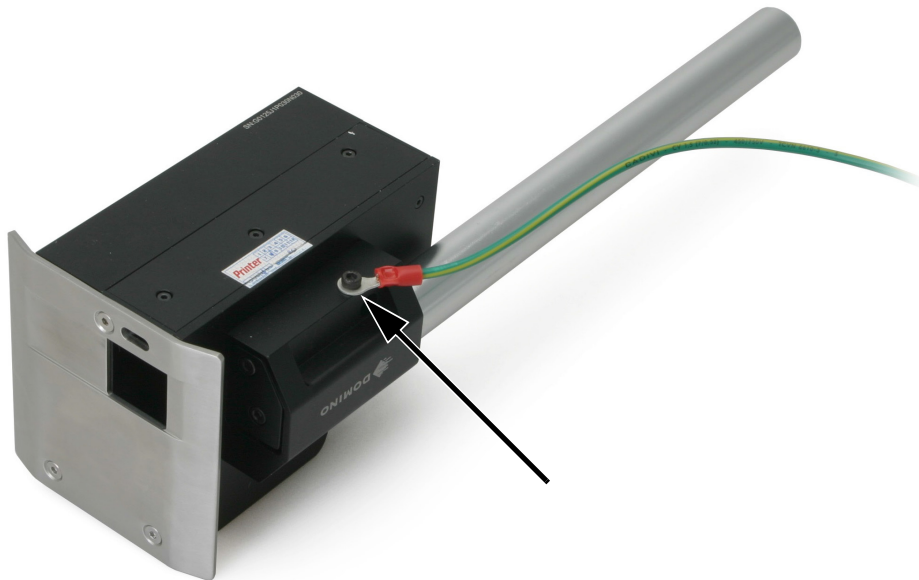

G20i Ground Point

- (2) Attach the other end of the ground cable to suitable grounding point.

INSTALLATION

Power Supply Connection

CAUTION: *Only use the power adapter provided.*

- (1) Plug the power adapter into the 12 VDC socket.



Power Adapter Connection

- (2) Plug the power adapter into a wall outlet, or other power source.

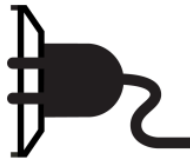

INSTALLATION

Wireless USB Keyboard Connection

- (1) Insert the USB keyboard receiver into the printer's USB keyboard slot.



Wireless USB Keyboard Receiver

- (2) Insert 2 x AAA batteries into the keyboard's battery compartment.



Wireless USB Keyboard Batteries

- (3) Turn on the keyboard.



Wireless USB Keyboard On/Off Switch

INSTALLATION

Ink Cartridge Installation

To install an ink cartridge into the G20i:

- (1) Open the latch on the rear of the printer.



Ink Cartridge Latch

- (2) Remove the cap from the ink cartridge.

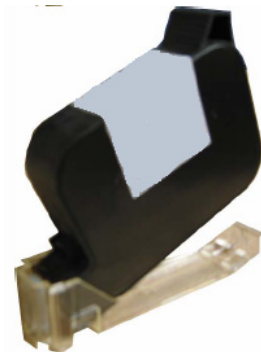

Ink Cartridge Cap

INSTALLATION

- (3) Insert the ink cartridge into the printer.

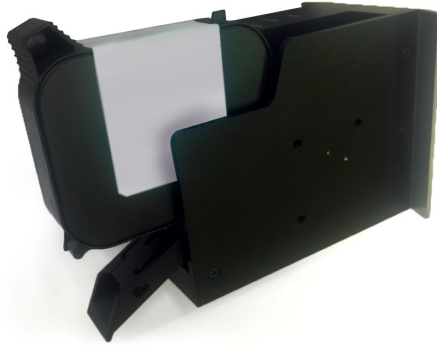

Insert Ink Cartridge

- (4) Close the latch on the rear of the printer.

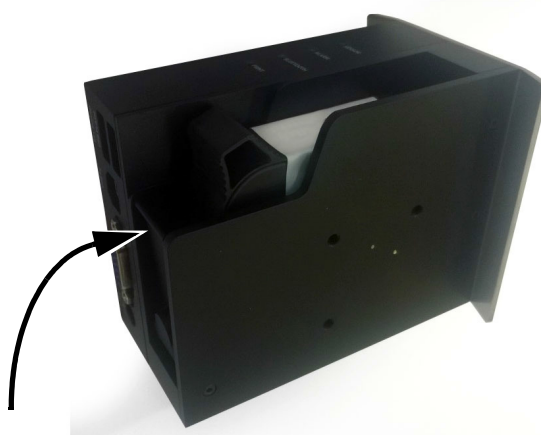

Close Ink Cartridge Latch

INSTALLATION

PC Connection and Software Installation

Notes: (1) The wireless USB Keyboard is required to set up the printer to PC connection.

- (2) If installing the software onto a computer operating Windows 8 or 10 64 bit, driver signature enforcement must be disabled before installing the driver. See [“Disable Driver Signature Enforcement”](#) on page 6-18.

To connect the G20i to a PC:

- (1) Save the Domino G20i software and driver files to a location on the PC.
- (2) Connect the PC to the USB PC slot on the G20i using the USB A-B Cable.

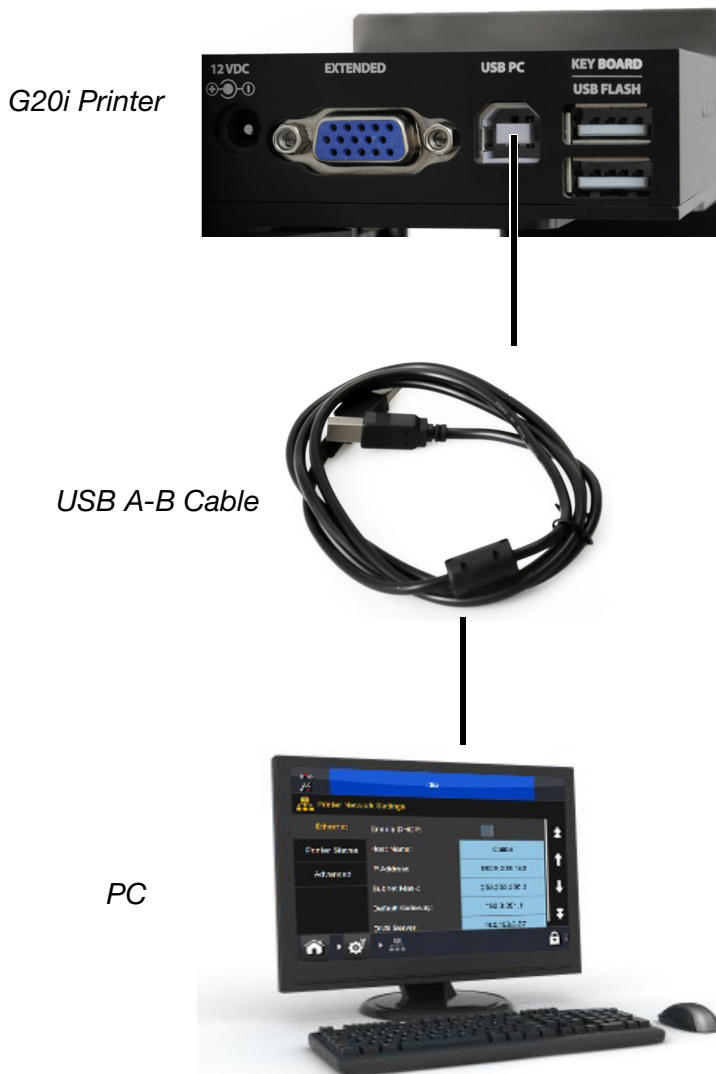

PC to G20i Connection Diagram

INSTALLATION

- (3) Turn the G20i on.
- (4) Using the wireless USB keyboard, from the printer's main menu, move the cursor down to highlight *Operation*.
- (5) Press the *Enter* button.
- (6) Move the cursor to highlight *Connect PC*.
- (7) Press the *Enter* button.
- (8) The PC should now detect the connection to the G20i and attempt to install the driver software, follow the on screen instructions.
- (9) If the PC does not automatically install the driver, the driver must be installed manually. [See "Manual Driver Installation" on page 6-19.](#)
- (10) Start the Domino G20i Setup programme on the PC and follow the on screen instructions.

Disable Driver Signature Enforcement

If the PC to which the G20i is being connected uses the Windows 8 or 10 64 bit operating system, driver signature enforcement must be disabled.

Windows 8

To disable driver signature enforcement in Windows 8:

- (1) Hold down the *Windows* button on the PC's keyboard and press the *C* button.
- (2) Click on *Settings*.
- (3) Click on *Change PC settings*.
- (4) Click on *General*.
- (5) Under *Advanced start-up*, click on *Restart now*.
- (6) After restarting, click on *Troubleshoot*.
- (7) Click on *Advanced options*.
- (8) Click on *Start-up Settings*.
- (9) Click on *Restart*.
- (10) After restarting, press the *F7* button on the PC's keyboard to disable driver signature enforcement.
- (11) The computer will now restart; after restarting, the driver can be installed.

Windows 10

To disable driver signature enforcement in Windows 10:

- (1) Click on the *Windows Start* icon.
- (2) Click on *Power*.
- (3) Hold down the *Shift* button on the PC's keyboard and click on *Restart*.
- (4) After restarting, click on *Troubleshoot*.
- (5) Click on *Advanced options*.
- (6) Click on *Startup Settings*.
- (7) Click on *Restart*.
- (8) After restarting, press the *F7* button on the PC's keyboard to disable driver signature enforcement.
- (9) The computer will now restart; after restarting, the driver can be installed.

Manual Driver Installation

To manually install the G20i driver:

- (1) Select the Windows start icon on the PC.
- (2) Right-click *Computer* and select *Manage*.
- (3) Select *Device Manager* in the left side bar.
- (4) Right-click on *Thermal Inkjet Coder* and select *Update Driver Software*.
- (5) Select *Browse my computer for driver software*.
- (6) Select the driver software location.
- (7) Select *Next*.
- (8) Follow the on screen instructions to install the driver.

Android Device Connection

Note: The wireless USB Keyboard is required to set up the Android device connection.

To set up the Android device connection:

- (1) Using the wireless USB keyboard, from the printer's main menu, move the cursor down to highlight *Settings*.
- (2) Press the *Enter* button.
- (3) Move the cursor to highlight *Bluetooth*.
- (4) Press the *Enter* button.
- (5) Ensure that *Active* is set to *Enable*.
- (6) Move the cursor to highlight *Name*.
- (7) Type in a name which will be used to identify the printer.
- (8) Move the cursor to highlight *Pin*.
- (9) Type in a pin number which will be used to access the printer.
- (10) Press the *Enter* button.
- (11) Press *ESC* to return to the main menu.
- (12) Download the Domino Printer G20i application from the Google Play store onto the Android device.
- (13) Turn on Bluetooth on the Android device.
- (14) Open the Domino Printer G20i application on the Android device.
- (15) Select *Printers*.
- (16) Select *Search for devices*.
- (17) When the printer is found, its name will appear in the *Available Devices* list.
- (18) Select the printer.
- (19) Select *Connect*.
- (20) Enter the printer's pin number.
- (21) Select *OK*.
- (22) Return to the Domino Printer G20i application's Home menu.
- (23) The printer is now ready to use.

INPUT CONNECTIONS

NPN Input Signal Connection



CAUTION:

Turn off the G20i and disconnect the power before making any wiring connections.

An NPN input signal can be connected to the Extended Port to trigger functions such as counter reset.

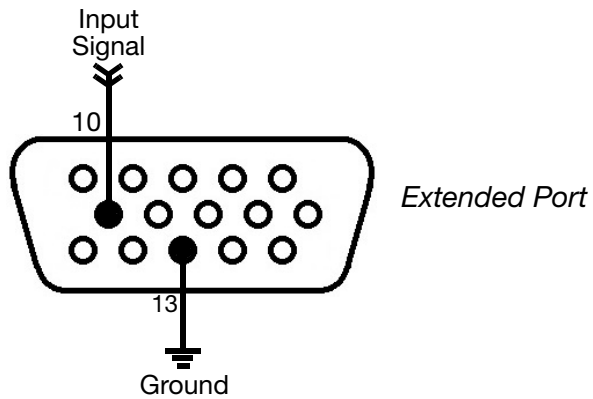

NPN Input Signal Wiring Diagram

External Product Sensors

The G20i supports NPN, PNP and Push-Pull sensor types. When connected, the sensor will send a print trigger signal to the G20i when the leading edge of a product passes the sensor.

When using an external product sensor, the product sensor type (page 6-42), print delay (page 6-44) and print mode (page 6-46) must be set.

NPN Product Sensor Connection



CAUTION:

Turn off the G20i and disconnect the power before making any wiring connections.

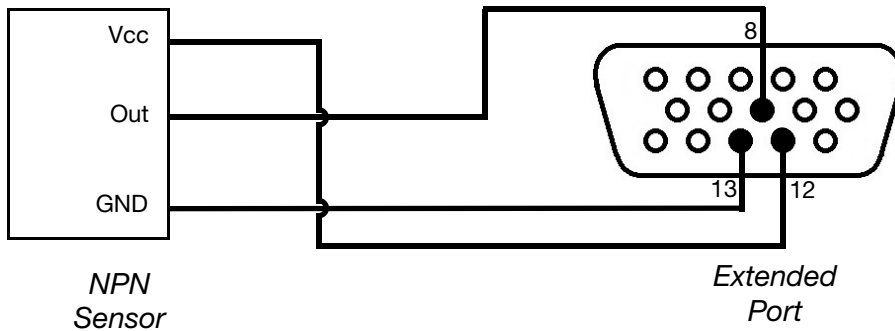

*NPN Sensor to Printer Wiring Diagram
(Powered from the printer)*

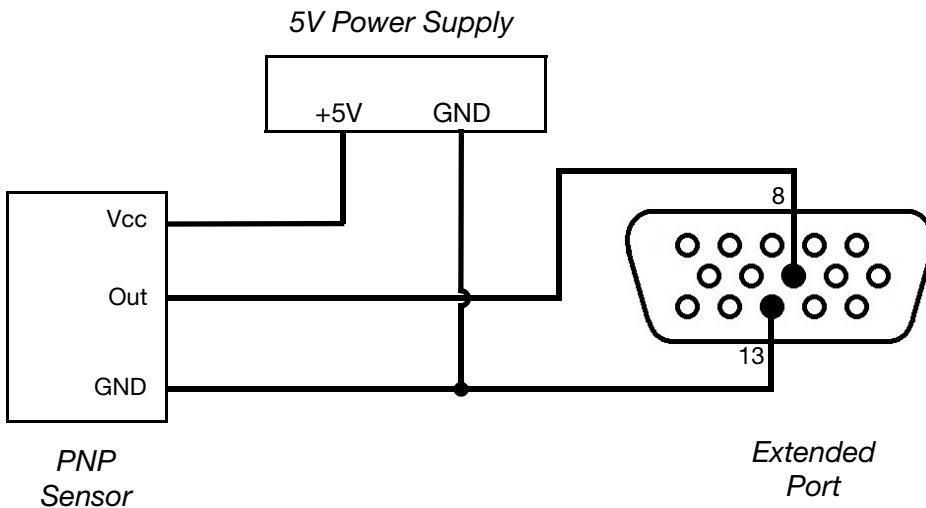

*NPN Sensor to Printer Wiring Diagram
(Powered from an external power supply)*

PNP Product Sensor Connection



CAUTION:

Turn off the G20i and disconnect the power before making any wiring connections.

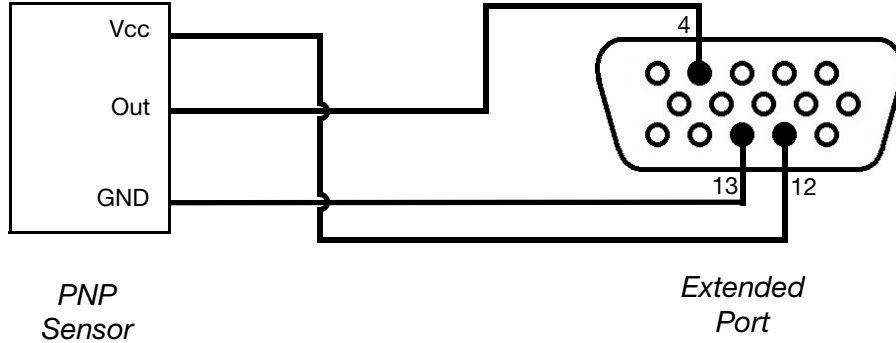

*PNP Sensor to Printer Wiring Diagram
(Powered from the printer)*

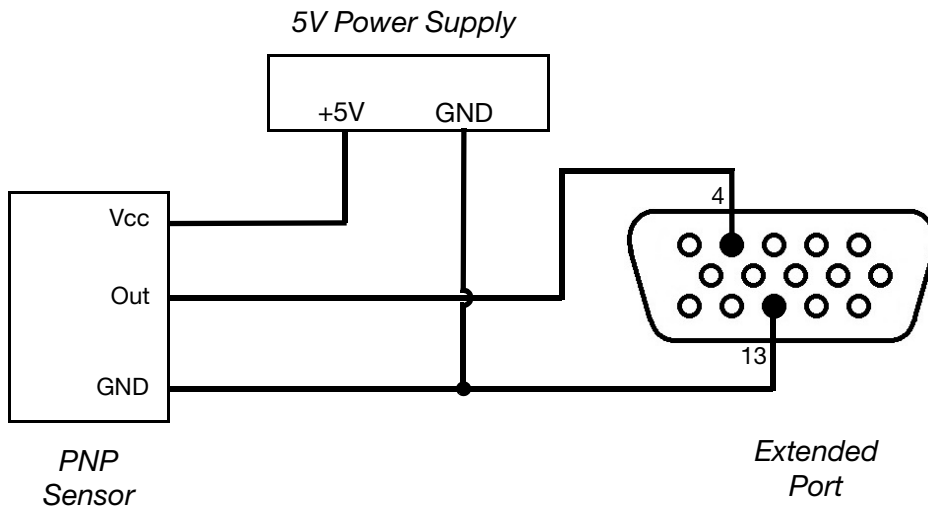

*PNP Sensor to Printer Wiring Diagram
(Powered from an external power supply)*

Push-pull Product Sensor Connection



CAUTION:

Turn off the G20i and disconnect the power before making any wiring connections.

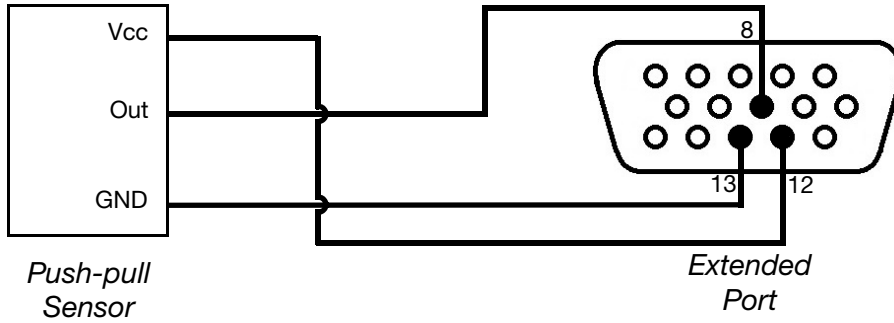

*Push-Pull Sensor to Printer Wiring Diagram
(Powered from the printer)*

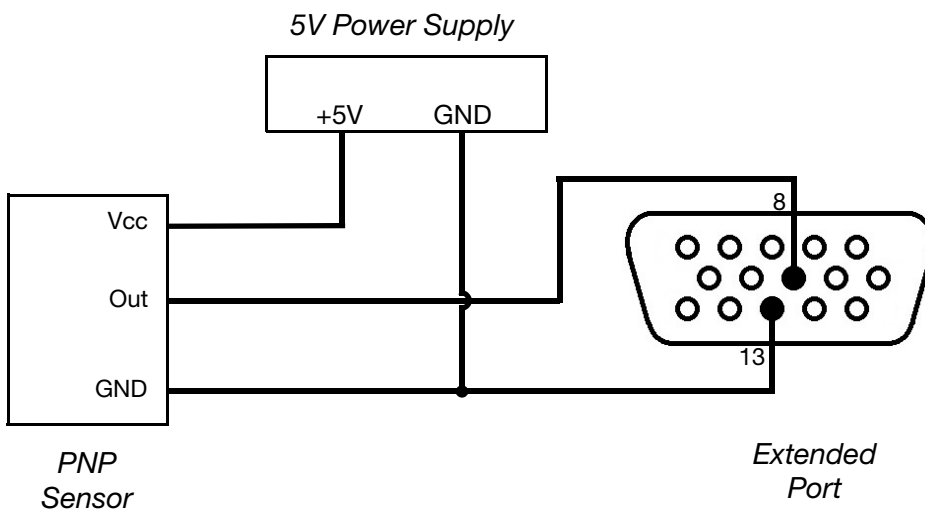

*Push-Pull Sensor to Printer Wiring Diagram
(Powered from an external power supply)*

OUTPUT CONNECTIONS

NPN Output Signal Connection



CAUTION:

Turn off the G20i and disconnect the power before making any wiring connections.

The printer can generate an NPN output signal from the Extended Port after each print.

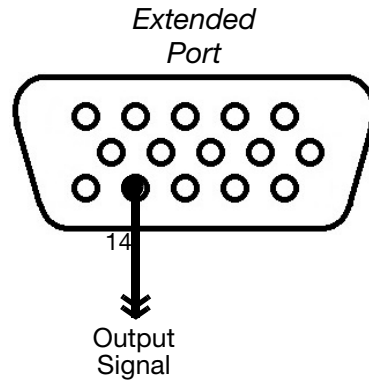

NPN Output Signal Wiring Diagram

Alarm Beacon Connection



CAUTION: Turn off the G20i and disconnect the power before making any wiring connections.

An alarm beacon can be connected to allow operators to monitor the printer's status from a distance.



Beacon Signal	Explanation
Red	There is a fault, printer has stopped.
Amber	The printer requires attention.
Green	The printer is printing or is ready to print.

Power: 12V

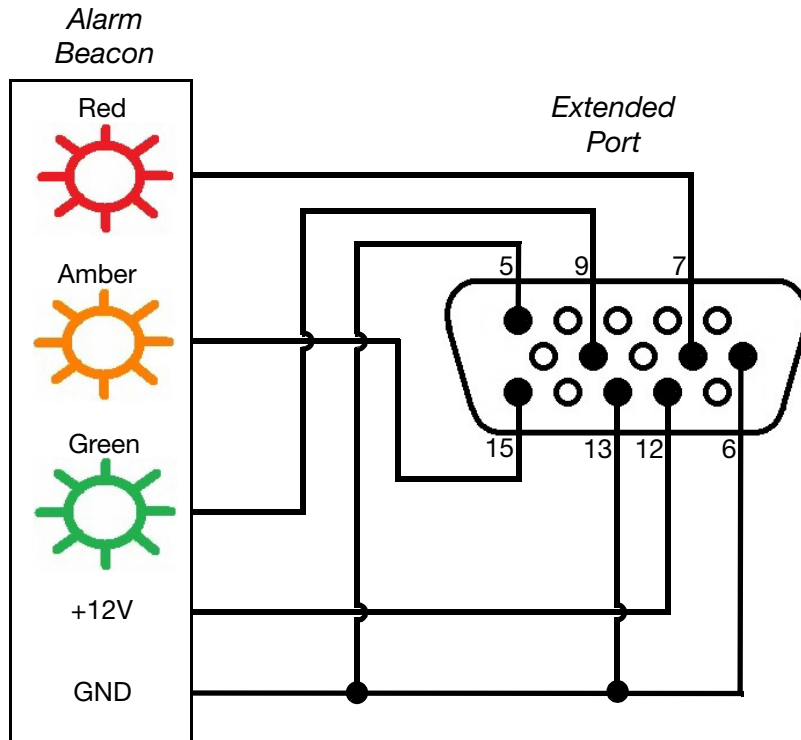

Alarm Beacon to Printer Wiring Diagram

Shaft Encoder Connection



CAUTION: Turn off the G20i and disconnect the power before making any wiring connections.

A shaft encoder can be connected to the G20i to measure the production line speed. A shaft encoder is recommended if the speed of the production line varies during printing.

Note: The G20i only supports fixed wheel shaft encoders, to calculate the required wheel diameter see [page 6-28](#).

Shaft Encoder Technical Specification	
Pulses Per Revolution:	3600
Outputs:	A B Z
Power:	12 - 24V

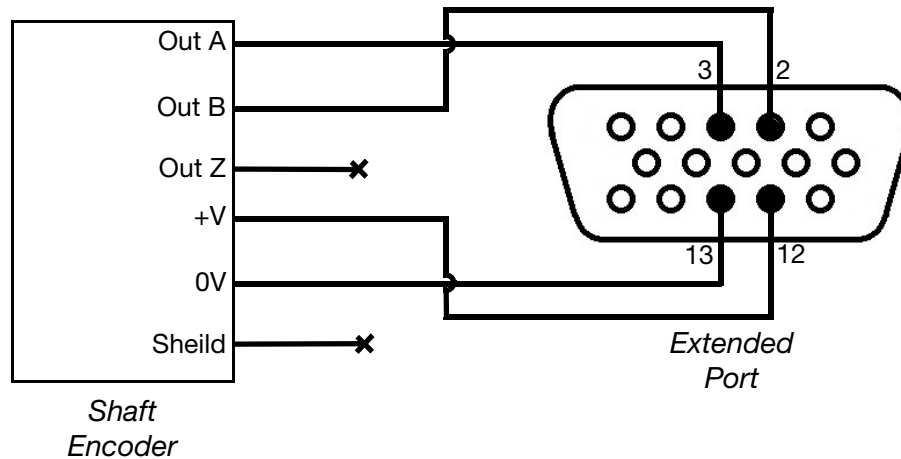

Shaft Encoder to Printer Wiring Diagram

Shaft Encoder Wheel Diameter

To calculate the required encoder wheel diameter (D), the required print resolution (R) must also be known.

Perform the following calculation:

$$3600 \div (\pi \times R) = D$$

For example, if the required printer resolution is 600DPI, the calculation for the encoder wheel diameter is:

$$3600 \div (\pi \times 600) = 1.90985 \text{ inches or } 48.5 \text{ mm.}$$

SHAFT ENCODER SET-UP

To use a shaft encoder, it must be set-up in the G20i's settings.

Using the Wireless USB Keyboard

To set-up the shaft encoder using the wireless USB keyboard:

- (1) From the main menu, highlight *Settings*.
- (2) Press the *Enter* button.
- (3) Move the cursor to highlight *Speed*.
- (4) Press the *Enter* button.
- (5) Move the cursor to highlight *Select*.
- (6) Press the *Enter* button.
- (7) Move the cursor to highlight *Encoder*.
- (8) Press the *Enter* button.
- (9) Move the cursor to highlight *Value*.
- (10) Press the *Enter* button.
- (11) Move the cursor to highlight *Real*.
- (12) Press the *Enter* button.

Using a PC

To set-up the shaft encoder using a PC:

- (1) Open the Domino G20i software.
- (2) Open the *Printer Control* menu.
- (3) Change the *Encoder* setting to *On*.

INTERNAL PRODUCT SENSOR

The G20i is equipped with an internal product sensor to trigger message printing.

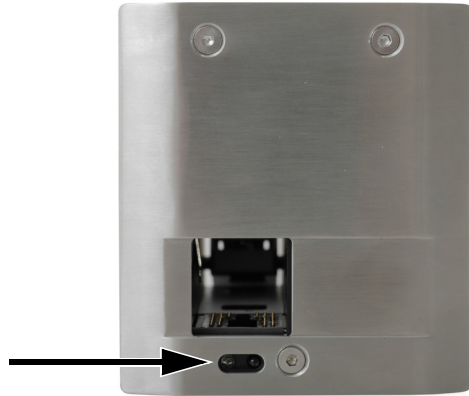

Internal Product Sensor Location

The internal product sensor will generate a print trigger signal when the leading edge of a product passes the product sensor.

To use the internal product sensor, the product sensor type ([page 6-42](#)), print delay ([page 6-44](#)) and print mode ([page 6-46](#)) must be set.

To calibrate the internal product sensor, see [“Internal Product Sensor Calibration”](#) on [page 6-31](#).

Internal Product Sensor Calibration

To calibrate the internal product sensor:

- (1) Place a product or box in front of the G20i so that it covers the product sensor.

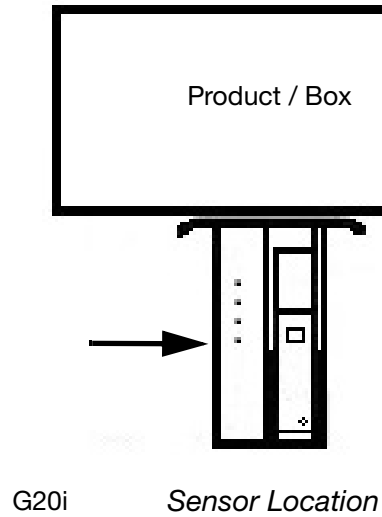

- (2) The Sensor LED should illuminate to indicate that a product has been detected.

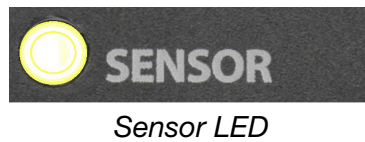

INSTALLATION

- (3) If the Sensor LED did not illuminate, use a small screwdriver to turn the adjustment screw clockwise, until the Sensor LED illuminates.



Adjustment Screw

- (4) Remove the product or box from in front of the internal product sensor.
- (5) The Sensor LED should now turn off. If the sensor LED does not turn off, turn the adjustment screw anti clockwise until the LED does turn off.

PRINTER SETTINGS

It is recommended to set the printer settings after the G20i has been installed.

Printing must be stopped whilst the printer settings are changed. See [“Stop Printing” on page 3-14.](#)

Set The System Clock

The system clock must be set to ensure that time and date fields are printed correctly.

The procedures below, describe how to set the system clock.

Using the Wireless USB Keyboard

To set the system clock using the wireless USB keyboard:

- (1) From the main menu, highlight *Settings*.
- (2) Press the *Enter* button.
- (3) Move the cursor to highlight *System clock*.
- (4) Press the *Enter* button.
- (5) Move the cursor to highlight *Date*.
- (6) Use the ← and → arrow buttons on the keyboard to change the date value.
- (7) Press the *Enter* button to apply the date value.
- (8) Move the cursor to highlight *Time*.
- (9) Use the ← and → arrow buttons on the keyboard to change the time value.
- (10) Press the *Enter* button to apply the time value.
- (11) Press the *ESC* button to return to the main menu.

Using a PC

Note: This feature is not available.

Using an Android Device

To set the system clock using an Android device:

- (1) Open the Domino Printer G20i application on the Android device.
- (2) Select *printer settings*.
- (3) Select *system clock*.
- (4) The system date and time can now be changed.
- (5) Select *set*.

Set the Unit of Measurement

The procedures below, describe how to set the measurement unit type that will be used in the printer.

Using the Wireless USB Keyboard

To set the measurement units using the wireless USB keyboard:

- (1) From the main menu, highlight *Settings*.
- (2) Press the *Enter* button.
- (3) Move the cursor to highlight *Unit*.
- (4) Press the *Enter* button.
- (5) Move the cursor to highlight either *inches* or *mm*.
- (6) Press the *Enter* button.
- (7) Press *ESC* to return to the main menu.

Using a PC

To set the measurement units using a PC:

- (1) Open the Domino G20i software.
- (2) Open the *Printer Control* menu.
- (3) Select the *Unit* drop-down menu.
- (4) Select either *Millimeters* or *Inches*.

Using an Android Device

To set the measurement units using an Android device:

- (1) Open the G20i application on the Android device.
- (2) Select *printer settings*.
- (3) Select *unit*.
- (4) Select either *Millimeter (mm)* or *Inches*.
- (5) Select *OK*.

Set the Print Direction

The procedures below, describe how to select which direction the product will pass across the print head, and which way up the message will be printed.

Using the Wireless USB Keyboard

To set the print direction using the wireless USB keyboard:

- (1) From the main menu, highlight *Settings*.
- (2) Press the *Enter* button.
- (3) Move the cursor to highlight *Direction*.
- (4) Press the *Enter* button.
- (5) Move the cursor to highlight a print direction:

ABC
CBA
CBA
ABC

- (6) Press the *Enter* button.
- (7) Press *ESC* to return to the main menu.

Using a PC

To set the print direction using a PC:

- (1) Open the Domino G20i software.
- (2) Open the *Printer Control* menu.
- (3) Select the *Direction* drop-down menu.
- (4) Select either *Left to Right* or *Right to Left*.
- (5) To print the message upside down, tick the *Rotate View* tick box.

Using an Android Device

To set the print direction using an Android device:

- (1) Open the G20i application on the Android device.
- (2) Select *printer settings*.
- (3) Select *print direction*.
- (4) Select a print direction:

ABC

CBA

CBA

ABC

- (5) Select *Cancel* to return to the printer settings menu.

Set the Print Density

The procedures below, describe how to set the print density.

A higher density setting will create a darker message, but will increase ink consumption and decrease the maximum print speed.

Using the Wireless USB Keyboard

To set the print density using the wireless USB keyboard:

- (1) From the main menu, highlight *Settings*.
- (2) Press the *Enter* button.
- (3) Move the cursor to highlight *Density*.
- (4) Press the *Enter* button.
- (5) Move the cursor to highlight a density level from 1 to 5.
- (6) Press the *Enter* button.
- (7) Press *ESC* to return to the main menu.

Using a PC

To set the print density using a PC:

- (1) Open the Domino G20i software.
- (2) Open the *Printer Control* menu.
- (3) Select a *Density* level from 1 to 5.

Using an Android Device

To set the print density using an Android device:

- (1) Open the G20i application on the Android device.
- (2) Select *printer settings*.
- (3) Select *density*.
- (4) Use the slider to select a density level from 1 to 5.
- (5) Select *Set*.

Set the Print Resolution (DPI)

The procedures below, describe how to set the print resolution (DPI).

Increasing the print resolution will increase print quality but will decrease the maximum print speed.

Using the Wireless USB Keyboard

To set the print resolution using the wireless USB keyboard:

- (1) From the main menu, highlight *Settings*.
- (2) Press the *Enter* button.
- (3) Move the cursor to highlight *Resolution*.
- (4) Press the *Enter* button.
- (5) Move the cursor to highlight the required resolution:
 - 300x300 DPI
 - 300x150 DPI
 - 300x100 DPI
- (6) Press the *Enter* button.
- (7) Press *ESC* to return to the main menu.

Using a PC

To set the print resolution using a PC:

- (1) Open the Domino G20i software.
- (2) Open the *Printer Control* menu.
- (3) Select the *Resolution DPI* drop-down menu.
- (4) Select the required resolution:
 - 600x600
 - 600x300
 - 600x150
 - 600x100
 - 300x300
 - 300x150
 - 300x100

Using an Android Device

To set the print resolution using an Android device:

- (1) Open the G20i application on the Android device.
- (2) Select *printer settings*.
- (3) Select *resolution*.
- (4) Select the required resolution:
 - 300x300 dpi
 - 300x150 dpi
 - 300x100 dpi
- (5) Select *OK*.

Set the Print Speed

The procedures below, describe how to manually set the print speed.

If the printer is not using a shaft encoder to measure print speed, the print speed must be manually set.

Note: It is recommended to use a shaft encoder to measure print speed if the production line speed varies.

The minimum speed which can be set is 0.1m/min.

The maximum speed which can be set is 228m/min, but this is dependant on the print density and print resolution settings, shown in the table below.

Density \ Resolution	1	2	3	45	5
300x300	76m/min	38m/min	25m/min	19m/min	15m/min
300x150	152m/min	76m/min	50m/min	38m/min	30m/min
300x100	228m/min	152m/min	101m/min	76m/min	60m/min

Using the Wireless USB Keyboard

To set the print speed using the wireless USB keyboard:

- (1) From the main menu, highlight *Settings*.
- (2) Press the *Enter* button.
- (3) Move the cursor to highlight *Speed*.
- (4) Press the *Enter* button.
- (5) Type in the speed of the production line conveyor (m/min).
- (6) Press the *Enter* button.
- (7) Press *ESC* to return to the main menu.

Using a PC

To set the print speed using a PC:

- (1) Open the Domino G20i software.
- (2) Open the *Printer Control* menu.
- (3) In the *Speed* text box, type the speed of the production line conveyor (m/min).

Using an Android Device

To set the print speed using an Android device:

- (1) Open the G20i application on the Android device.
- (2) Select *printer settings*.
- (3) Select *print speed*.
- (4) Use the slider to select the speed of the production line conveyor (m/min).
- (5) Select *OK*.

Set the Product Sensor Type

The procedures below, describe how to select either the internal or an external product sensor in the G20i's settings.

Using the Wireless USB Keyboard

To set the product sensor type using the wireless USB keyboard:

- (1) From the main menu, highlight *Settings*.
- (2) Press the *Enter* button.
- (3) Move the cursor to highlight *Sensor*.
- (4) Press the *Enter* button.
- (5) Move the cursor to highlight either:
 - *Internal* - To use an internal product sensor; or,
 - *External* - To use an external product sensor.
- (6) Press the *Enter* button.

Using a PC

To set the product sensor type using a PC:

- (1) Open the Domino G20i software.
- (2) Open the *Printer Control* menu.
- (3) Change the Printing Mode to *Sensor*.
- (4) Change the Sensor Mode Type to either:
 - *Internal* - To use an internal product sensor; or,
 - *External* - To use an external product sensor.

Using an Android Device

To set the product sensor type using an Android device:

- (1) Open the Domino Printer G20i application on the Android device.
- (2) Select *printer settings*.
- (3) Select *sensor*.
- (4) Select either:
 - *Internal sensor* - To use an internal product sensor; or,
 - *External sensor* - To use an external product sensor.
- (5) Select *Set*.

Set the Print Delay

The procedures below, describe how to set the print delay values.

The print delay values, set the distance between when a print trigger signal is received by the G20i and the point when a message is printed.

The print delay values also set the distance between printed messages.

Using the Wireless USB Keyboard

To set the print delay using the wireless USB keyboard:

- (1) From the main menu, highlight *Settings*.
- (2) Press the *Enter* button.
- (3) Move the cursor to highlight *Delay*.
- (4) Press the *Enter* button.
- (5) Change the *Delay Before* value to set the distance between when the print trigger is activated, and the point when the message will print. (5mm to 500mm)
- (6) Change the *Delay After* value to set the distance between when the message has finished printing, and when the next message will start printing. (50mm to 500mm)
- (7) Press the *Enter* button.

Using a PC

To set the print delay using a PC:

- (1) Open the Domino G20i software.
- (2) Open the *Printer Control* menu.
- (3) Under the *Sensor* tab, change the *Delay Before* value to set the distance between when the print trigger is activated, and the point when the message will print. (5mm to 500mm)
- (4) Under the *Sensor* tab, change the *Delay After* value to set the distance between when the message has finished printing, and when the next message will start printing. (50mm to 500mm)

Using an Android Device

To set the delay using an Android device:

- (1) Open the Domino Printer G20i application on the Android device.
- (2) Select *printer settings*.
- (3) Select *print delay*.
- (4) Change the *Delay before print* value to set the distance between when the print trigger is activated, and the point when the message will print. (5mm to 500mm)
- (5) Change the *Delay After* value to set the distance between when the message has finished printing, and when the next message will start printing. (50mm to 500mm)
- (6) Select *Set*.

Set the Print Mode

The procedures below, describe how to set the G20i's print mode.

The G20i has 2 print modes:

Print Mode	Explanation
Sensor Mode	The G20i will print 1 or more messages after each pulsed input signal is received from a product sensor.
Continue Mode	The G20i will be triggered to print messages from a continuous input signal from a product sensor. Printing will only stop when the input signal stops.

Using the Wireless USB Keyboard

Sensor Mode

To set the print mode as Sensor, using the wireless USB keyboard:

- (1) From the main menu, highlight *Settings*.
- (2) Press the *Enter* button.
- (3) Move the cursor to highlight *Print Mode*.
- (4) Press the *Enter* button.
- (5) The following settings can now be configured.

Mode:	Select <i>Sensor</i> .
Repeat:	Enter the number of times a message should be repeated after each input signal. (0 - 100)
Delay:	Enter the distance between each printed message. (10 - 10,000)

- (6) Press the *Enter* button.

INSTALLATION

Continue Mode

To set the print mode as Continue, using the wireless USB keyboard:

- (1) From the main menu, highlight *Settings*.
- (2) Press the *Enter* button.
- (3) Move the cursor to highlight *Print Mode*.
- (4) Press the *Enter* button.
- (5) The following settings can now be configured.

Mode:	Select Continue.
Delay:	Enter the distance between each printed message. (10 - 10,000)
Enable:	Select either: Level - A sensor signal will be required to start printing. Immediate - The G20i will start printing immediately after <i>Start</i> is selected from the <i>Message</i> menu.

- (6) Press the *Enter* button.

Using a PC

Sensor Mode

To set the print mode as Sensor using a PC:

- (1) Open the Domino G20i software.
- (2) Open the *Printer Control* menu.
- (3) Change the *Printing Mode* to *Sensor*.
- (4) The following settings can now be configured:

Type:	Select either: <ul style="list-style-type: none"> • External - if an external product sensor is used to trigger printing. • Internal - if an internal product sensor is used to trigger printing.
Delay:	Change the <i>Before</i> value to set the distance between when the trigger signal is received and when the first message is printed. (10 - 10,000) Change the <i>After</i> value to set the distance between messages. (10 - 10,000)
Repeat Sensor:	Enter the number of times a printed message should be repeated. (0 - 99)
Fixed Length:	Enter the distance between repeated messages. (10 - 10,000)

Continue Mode

To set the print mode as Continue using a PC:

- (1) Open the Domino G20i software.
- (2) Open the *Printer Control* menu.
- (3) Change the *Printing Mode* to *Continue*.
- (4) Change the Fixed Length value to the distance between each printed message. (10 - 10,000)
- (5) If the printed message is not to be repeated, tick the *No repeat data* tick box.

Using an Android Device

Sensor Mode

To set the print mode as Sensor using an Android device

- (1) Open the G20i application on the Android device.
- (2) Select *printer settings*.
- (3) Select *print mode*.
- (4) Tick the *Use sensor mode* tick box.
- (5) The following settings can now be configured:

Delay (mm):	Enter the distance between each printed message. (10 - 10,000)
Repeat time:	Enter the number of times the message should be repeated.

- (6) Select *Set*.

Continue Mode

To set the print mode as Continue using an Android device

- (1) Open the G20i application on the Android device.
- (2) Select *printer settings*.
- (3) Select *print mode*.
- (4) Un-tick the *Use sensor mode* tick box.
- (5) Set the *Delay (mm)* value to the distance between each printed message.
- (6) Select *Set*.

Set Password Protection

The G20i can be password protected to prevent an unauthorised user accessing the printer settings.

Notes: (1) By default the G20i's password protection is disabled.

(2) The default password is: 1234567890.

(3) A password can be up to 10 alphanumeric characters in length.

(4) A wireless USB keyboard is required to set password protection.

To set the password protection:

- (1) From the main menu, highlight *Settings*.
- (2) Press the *Enter* button.
- (3) Move the cursor to highlight *Password*.
- (4) Press the *Enter* button.
- (5) Move the cursor to highlight *Active*.
- (6) Press the *Enter* button.
- (7) Enter the old password.
- (8) Press the *Enter* button.
- (9) Enter the new password.
- (10) Press the *Enter* button.
- (11) Retype the new password
- (12) Press the *Enter* button.
- (13) Press *ESC* to return to the main menu.